

**Seminar 2**

**Oceans as a Source of Renewable Energy**

*Hawaii, USA, March 26-28, 2012*

## An Overall Picture of the Marine Renewable Energy and Innovation Policies

**Henri Boyé**, General Council for Environment and Sustainable Development, French Ministry of Ecology and Energy, Chairman of the EMACOP Project, France

The purpose of this paper is to give an overall picture of the marine renewable energy. The new sources of energy from the oceans (thermal, wave, tidal, currents, wind, biomass, etc.) are very interesting for those living near the Pacific Ocean, and particularly to those on islands with limited resources or limited access to means to meet their increasing needs in energy, due to rising population and needs for economic development.

### 1. Multiple dimensions

There are multiple dimensions to consider when it comes to exploring marine renewable energy (MRE). What are the technologies available? What is the current level of competitiveness vis-à-vis other sources of energy? What could we realistically expect to become economically viable? Which new technologies and industries should we first invest in to maximize energy available from the ocean? Which mechanisms and incentives are the most efficient and appropriate for the development of marine renewable energies?

From technical potentialities to economic reality, what are the best ways to increase the use of energy from marine sources? How should one plan a timetable to promote new marine technologies, from research and development to industrial implementation, with a cost-efficiency approach (research, incentives, etc.)?

Renewable energies dominated globally prior to the 20<sup>th</sup> century. There were only wood, watermills, windmills, slaves and horses, representing 100% of total energy prior to the 19<sup>th</sup> century. During the 19<sup>th</sup> century coal and steam engines appeared. In the 20<sup>th</sup> century, oil, gas, nuclear became dominant. Can we go back to renewable energy? How?

### 2. An overall picture of the marine renewable energy

As far as ocean renewable energies are concerned, a wide range of technologies is currently being experimented with, including wind power and energy derived from waves and tidal currents. They are at varying levels of maturity, accompanied by very different technical and economic challenges.

The most common of these renewable energies is currently wind power, which is harnessed at offshore sites. Oceans provide several other energy sources which can be exploited, such as the tides and currents, as well as the waves and the thermal energy that reside in the seas. The oceans' salinity gradients can also be harnessed, or algae cultivated in order to produce the so-called third-generation biofuels ("Water and biofuels," *Panorama*, 2011), but these sectors are currently in their infancy.

In 2010, renewable energies accounted for nearly 20% of our overall energy consumption. Ocean energies accounted for an infinitesimally small percentage, although the theoretical potential remains huge. There are hundreds of existing patents in the marine renewable energy sector. In this profusion of technologies, often competing against one another, a selection is needed.

Figure 1. Ocean energy-related research, demonstration and commercial activities (December 2007)

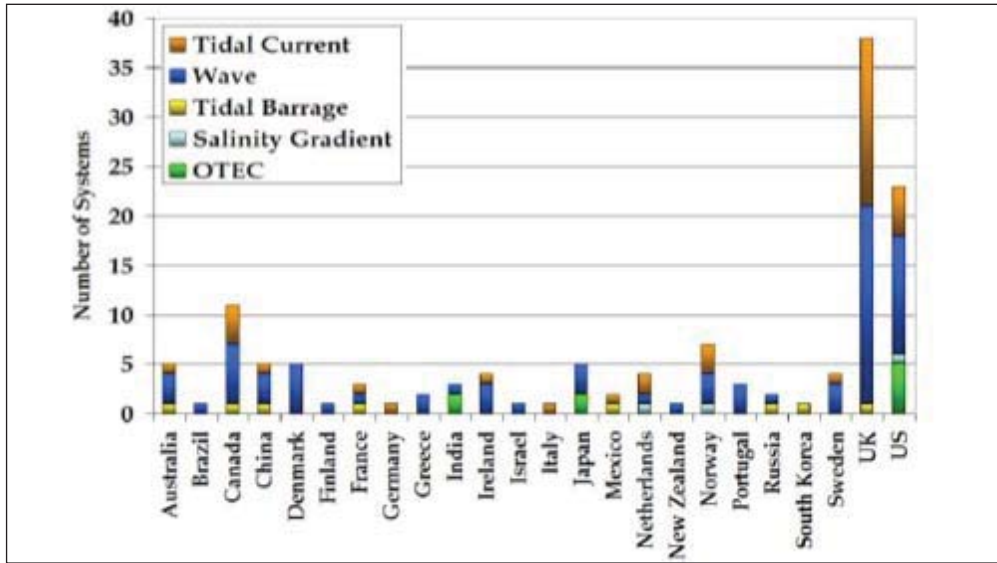

2.1. Tidal power

Tidal power is undoubtedly the most developed of these at the moment. For example, the Rance dam in Brittany (France) has been supplying a significant amount of energy (240 MW of installed capacity, providing approximately 500 GWh/year) to the network since 1977. Very few installations have been developed since then, with only a few sites of this type in operation in Canada, China, Russia and South Korea (where the world's most powerful tidal power facility was built in 2009 at Lake Sihwa with an installed capacity of 254MW and inaugurated on 29<sup>th</sup> August 2011 by the President of the Republic of Korea).

Limited availability of suitable sites is preventing tidal power from being more readily adopted, in addition to significant financial challenges, which have led to cancellation of some projects such as the Severn Barrage in the UK.

2.2. Offshore wind farms and floating windmills

Currently, offshore wind farms are being installed only near coastlines. However, in order to take advantage of considerably greater wind power, floating wind farm technologies are needed. Developing floating structures is still a challenge. In Europe, an increasing number of wind power demonstration projects are being developed in a bid to put forward concepts that are technologically safe and economically viable. Some examples are: Project Diwet, WindSea, and Sway. Two interesting projects involve French companies: Winflo project, run by Nass & Wind<sup>1</sup>, involves a floating wind farm on a semi-submerged platform, while the VertiWind project, run by Nenuphar<sup>2</sup>, is developing an innovative concept that involves a vertical axis floating wind farm.

Theoretically, there is a huge potential in gathering offshore marine energy from the North Sea for example, to meet the needs of Europe. However, development of offshore wind power sector is still being slowed down by technological obstacles (even more so for the floating wind power sector), and it is still very dependent on subsidies and feed-in tariffs which need to be introduced in order to

<sup>1</sup> [http://nassetwind.com/?page\\_id=20&lang=en\\_gb\\_FR](http://nassetwind.com/?page_id=20&lang=en_gb_FR)

<sup>2</sup> <http://www.nenuphar-wind.com/press>

enable the sector. The key is to find a solution that promises to become most economically viable in the future.

### 2.3. *Modern technology in wave energy*<sup>3</sup>

Wave power devices are generally categorized by the method used to capture the energy of the waves; by location and by the power take-off system. Method types are: point absorber or buoy, surface following or attenuator oriented in parallel to the direction of wave propagation; terminator, oriented perpendicular to the direction of wave propagation; oscillating water column; and overtopping. Locations are shoreline, near-shore and offshore. Types of power take-off include: hydraulic ram, elastomeric hose pump, pump-to-shore, hydroelectric turbine, air turbine, and linear electrical generators. A number of systems have been devised and tested. They fall into two main categories: fixed versions (anchored to the seabed, near-shore, or on coast) and floating versions.

Historically, the first of these systems to be developed was the oscillating wave column system. Collecting systems are also used in a number of cases: by collecting water moved by the waves in raised reservoirs, a bidirectional turbine can be operated by the flow generated. Currently, however, it is systems which involve oscillating bodies - usually buoys - that are attracting the most amount of interest. Set up at sea, they have to be capable of recovering the most amount of energy possible while at the same time being robust enough to withstand storms and freak waves. This creates a number of challenges with respect to their structure and how they are anchored.

Some practical factors should be taken into consideration in wave energy:

- It is necessary to increase demonstrations at sea (only real sea operation will allow identification of best solutions vis-à-vis reliability and cost).
- Test centers are necessary to improve materials, components and power take-off equipment (failures to date are related to components and not the basic concept).
- We need to improve design, monitoring and control methods, as well as tools for single devices and farms (demonstrations at sea are very expensive and risky).
- We also need to improve fabrication, deployment, O&M methods and tools, including support vessels (cost reductions by a factor of 3 are to be attained).

### 2.4. *Ocean current power technology*

The currents which result from tides are particularly strong in certain areas near the coast, such as straits, headlands and estuaries. This energy can be converted into electricity by marine current turbines, gathered in underwater wind farms. About a third of them are axial flow installations (with geometry that is very similar to the familiar wind farm design), while the remainder are cross flow installations, i.e. fitted with a vertical rotation axis. Other concepts exist, such as Venturi effect turbines and oscillating systems.

Over the last fifty years, there have been numerous inventions suggested for extraction of the large ocean currents, like the Gulf Stream. Since the ocean currents are slow (1-2m/s) and the inherent energy is cubed to the velocity, much can be won by increasing the actual flow over the turbine during power extraction, by different designs, where the most common one has been to construct a ducted shroud over the turbine. With a duct the water flow is dragged through the turbine by the experienced pressure gradient that develops from the shape of the duct and the increase in velocity becomes reflected in the conversion efficiency of the device.

---

<sup>3</sup> See: <http://www.carnegiewave.com>  
<http://www.pelamiswave.com>  
<http://www.aquamarinepower.com>

Among many, here are some examples of technologies being tested and further developed:

[www.ocean-energy-systems.org/library/annual\\_reports/2011\\_annual\\_report](http://www.ocean-energy-systems.org/library/annual_reports/2011_annual_report)

[www.ocean-energy-systems.org/about\\_oes/oes\\_vision\\_brochure](http://www.ocean-energy-systems.org/about_oes/oes_vision_brochure)

Open Hydro	<a href="http://www.openhydro.com">www.openhydro.com</a>
Alstom Power	<a href="http://www.alstom.com/power/renewables/ocean-energy/tidal-energy">www.alstom.com/power/renewables/ocean-energy/tidal-energy</a>
Hydroome	<a href="http://www.ecocinetic.fr">www.ecocinetic.fr</a>
Harvest	<a href="http://www.grenoble-inp.fr/recherche">www.grenoble-inp.fr/recherche</a>
Tocado	<a href="http://www.tocado.com">www.tocado.com</a>
Ecofys Wave Rotor	<a href="http://www.c-Energy.nl">www.c-Energy.nl</a>
Hydro-Gen	<a href="http://www.hydro-gen.fr">www.hydro-gen.fr</a>
Blue Energy	<a href="http://www.bluenergy.com">www.bluenergy.com</a>
Blustream	<a href="http://www.gazintegral.com/blustream">www.gazintegral.com/blustream</a>
Scotrenewables	<a href="http://www.scotrenewables.com">www.scotrenewables.com</a>

An example of tidal stream in an atoll pass is the Atoll of Hao in the Tuamotu. The lagoon of Hao is one of the biggest in Polynesia, and opens to the Pacific Ocean by a unique pass (the Kaki pass at its northern extreme point), where the tidal current may reach 20 knots per hour.

### 2.5. *Ocean thermal energy conversion (OTEC)*

OTEC technologies make use of temperature differences between water at the surface and bodies of water deeper down. A temperature differential of at least 20°C between the waters is required, and so these technologies are mainly associated with the world's inter-tropical zones. By heat exchange technology, this temperature difference ( $\Delta T$ ) can be utilized to drive electricity generating turbines. Power can be generated on base load, 24/7. The energy potential is enormous, around 10,000 TWh/year, close to the annual electricity consumption in 2000. However, a technical difficulty exists: the cold water pipe. A number of other companies are also exploring ways of using cold water at the bottom of the oceans either for air conditioning buildings or liquefying natural gas.

A feasibility study has just been approved for an OTEC electricity plant in French Polynesia. On Reunion and Martinique Islands another project is underway which will involve France's naval defense company, DCNS, building a demonstrator. And in the USA, Lockheed Martin, a specialist aeronautics and defense group, is also showing an interest in the subject.

Osmotic power or salinity gradient power is energy generated from differences in salt concentration between seawater and river water. The process relies on osmosis with ion-specific membranes as the result of natural forces that are being harnessed: the flow of fresh water into seas that are made up of salt water. There is a pilot concept in Norway, an idea in Reunion Island at Sainte Rose.

## 3. Which policy for innovation? And how to overcome the barriers?

### 3.1 *Public policies and barriers*

A large number of barriers can be identified, most of which may be removed or significantly reduced with proper public policies: simplified licensing procedures for projects and entrepreneurs. Some barriers are:

- Access to the electrical grid, access to field data;
- Development of a domestic market: with feed-in tariffs? Define domestic market (what percentage of energy mix?) In spite of very high expectations on wave energy, at present, costs are high and no operational experience is yet available;

- The cost and financing of renewable energies; and
- Financing. What is the cost now? Cost tomorrow? Who pays for what? Feed-in tariffs or targeted grants? For R&D, questions remain on industrial policies and manufacturing aspects.

### 3.2. *Stakes for development of MRE, building an industry, financing and incentives*

R&D grants are the most important ingredient in stimulating the R&D industry. Test sites are important infrastructures where the commercial designs can be validated. Test sites are usually government-funded facilities.

Revenue support: in order for targets to be met and to attract developers, revenue support schemes have been developed and implemented in many European countries. The most popular schemes now fall into two categories: feed-in tariffs (FIT) and renewable energy certificates (ROCs).

#### 3.2.1. *Non-technical barriers for MRE*

- Grid connection - there are two major barriers faced with grid connection: grid connection charges and grid capacity.
- Regulatory barriers -a successful manufacturing industry requires healthy national R&D as well as a local development industry which will provide a guaranteed home market for its products.
- Logistical barriers - Development Service ports and O/M personnel: easy access to service ports and availability of skilled service personnel with appropriate equipment are essential ingredients for a development and deployment industry in MRE.
- Financial barriers - R&D, manufacturing and development cost evaluation of a project is often left to the last stage of a project valuation, and the most important factor is the cost of materials and reliability.
- Other barriers are conflict of use and environmental impact.

#### 3.2.2. *Financing and incentives for MRE*

What are the available mechanisms? Which support instruments for renewable electricity are currently being implemented (in the individual member states of the EU)?

We distinguish three main support instruments: (1) investment-based mechanisms (e.g. subsidies, credits, and loans), (2) quota systems (Tradable Green Certificates, tendering), and (3) fixed price systems (feed-in tariffs).

#### 3.2.3. *Feed-in tariff (FIT)*

Feed-In tariffs are a policy mechanism designed to accelerate investment in renewable energy technologies. It achieves this by offering long-term contracts to renewable energy producers, typically based on the cost of generation of each technology. Technologies such as wind power, for instance, are awarded a lower per-kWh price, while technologies such as solar PV and tidal power are offered a higher price, reflecting higher costs.

FITs typically include three key provisions: guaranteed grid access, long-term contracts for the electricity produced, and purchase prices based on the cost of generation.

Some examples are:

- Portugal, with feed-in tariff for marine renewable energy at 0.33 Euro/kWh.
- USA, where the National Energy Act (NEA) including the Public Utility Regulatory Policies Act (PURPA) encourages energy conservation and the development of new energy resources,

including renewable ones. There are different tariffs for peak, baseload, and intermittent usage.

#### **4. Conclusion**

The big industrial challenges of marine energy are mainly based around its level of maturity, obtaining reduced cost from economies of scale and concentrating the incentives and public innovation on the best technologies.

This is not an easy job and there is proliferation of technologies, often competing against one another, whereby a selection becomes necessary. However, we can be optimistic for the future, as there are many possibilities to access and utilize new sources of energy from the ocean.

#### **References**

IFP Energies Nouvelles, Water and Biofuels *Panorama 2011*  
[www.ifpenergiesnouvelles.com/content/download/70600/1513822/version/2/file/Panorama2011\\_10-VA\\_Eau-Biocarburants.pdf](http://www.ifpenergiesnouvelles.com/content/download/70600/1513822/version/2/file/Panorama2011_10-VA_Eau-Biocarburants.pdf)  
[www.emec.org.uk](http://www.emec.org.uk)  
[www.france-energies-marines.org](http://www.france-energies-marines.org)

## Ocean Thermal Energy Conversion (OTEC): Challenges and opportunities

**Gérard C. Nihous**, Associate Professor, Department of Ocean and Resources Engineering, University of Hawaii, Honolulu, Hawaii, USA

### Abstract

*Ocean Thermal Energy Conversion (OTEC) resources across most of the tropical Pacific region are exceptionally good and stable. To date, however, no commercial OTEC system has been deployed anywhere. The fact that OTEC projects are capital-intensive by design and the specific risks associated with offshore operations have been invoked as the main obstacles hampering the development of this renewable technology. While these are valid arguments, the location of OTEC resources in tropical areas may further limit the interest of wealthy, technologically advanced stakeholders. To advance the technical state-of-the-art, 5 to 10MW floating pilot plants should be deployed and operated for a few years. The financial burden and other challenges associated with these next steps may also represent a unique opportunity for cooperation among Pacific economies.*

### 1. OTEC technology

Ocean Thermal Energy Conversion (OTEC) consists of a thermodynamic engine operated between a heat source and a heat sink provided by seawater drawn from different depths. Practical seawater temperature differences for OTEC plants are around 20°C. As illustrated in Figure 1, this thermal resource is available in most tropical regions where the ocean surface is warm. Cold-enough seawater originating from the polar margins is found at depths of the order of 1,000m. The OTEC region covers more than 120 million km<sup>2</sup>, with the greatest area in the central and western Pacific. Recent attempts to estimate the amount of extractable OTEC power given the potential impacts of OTEC seawater flows on the oceanic thermal structure suggest a sustainable range of 5 to 10TW (Nihous, 2007; Rajagopalan and Nihous, 2013a and 2013b).

**Figure 1.** Yearly average ocean temperature differences between 20m and 1000m

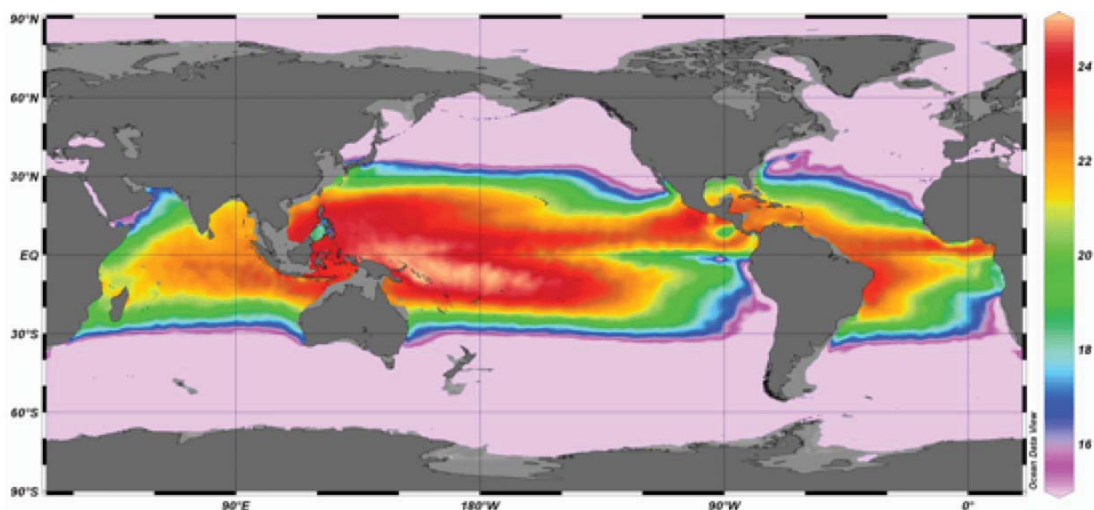

Source: adapted from Nihous (2010): WOA05 1/4° resolution data (Locarnini *et al.*, 2006), *Ocean Data View* plotting software (Schlitzer, 2009) with a color palette from 15°C to 25°C.



While this represents a tantalizing potential resource, most of it is located far offshore and, by design, in deep waters. These points immediately define a challenging environment, especially where the prevalence of tropical cyclones would not allow designers to relax the survival standards of their offshore equipment. This situation is exacerbated by the location of OTEC resources far away from most wealthy economies, for which immediate incentives to invest in OTEC development may be lacking. Even though historically, the same economies have not shied away from acquiring energy resources in distant regions, fossil fuels like oil represent a very different situation: many of the technological steps required for their utilization could be taken incrementally and often domestically. More crucial to the argument, however, is the exceptional energy density of fossil fuels (or fissile nuclear material) upon which modern societies have thrived. Most renewable energy technologies, and OTEC in particular are based on abundant and widespread resources, but they also require relatively large capture systems.

From a power-plant engineering perspective, the main distinctive characteristic of OTEC is that available temperature differences required are small (around 20°C). Given the ambient nature of the heat source, a standard OTEC plant based on a Rankine closed-cycle can be literally viewed as a refrigerator in reverse: in OTEC systems, an expanding turbine generates mechanical power as heat flows from the warm seawater to the cold seawater. In traditional refrigerators, a compressor consumes power to drive heat from the cold air (inside) to the warm ambient air (outside). In both cases, an auxiliary fluid mediates the transfer of heat (i.e., absorbing heat in an evaporator and rejecting heat in a condenser). Such a fluid must be able to change phases, from liquid to gas and vice-versa within the available temperature range. Ammonia is good example. A simplified heat-and-mass balance for a 10MW (net) OTEC plant is shown in Figure 2, where the working fluid closed loop is represented as a green line. Several important points can be made. On one hand, only about half of the available temperature difference (here, 10°C) can be used to directly generate power across the turbo-generator. The rest is needed to a) allow warm seawater to cool down as it releases heat and cold seawater to warm up as it absorbs heat, and b) to promote heat transfer in the heat exchangers (condenser and evaporator). All processes can be visualized as a temperature ladder.

Figure 2. Simplified heat-and-mass-balance of a 10MW OTEC plant (standard Rankine cycle)

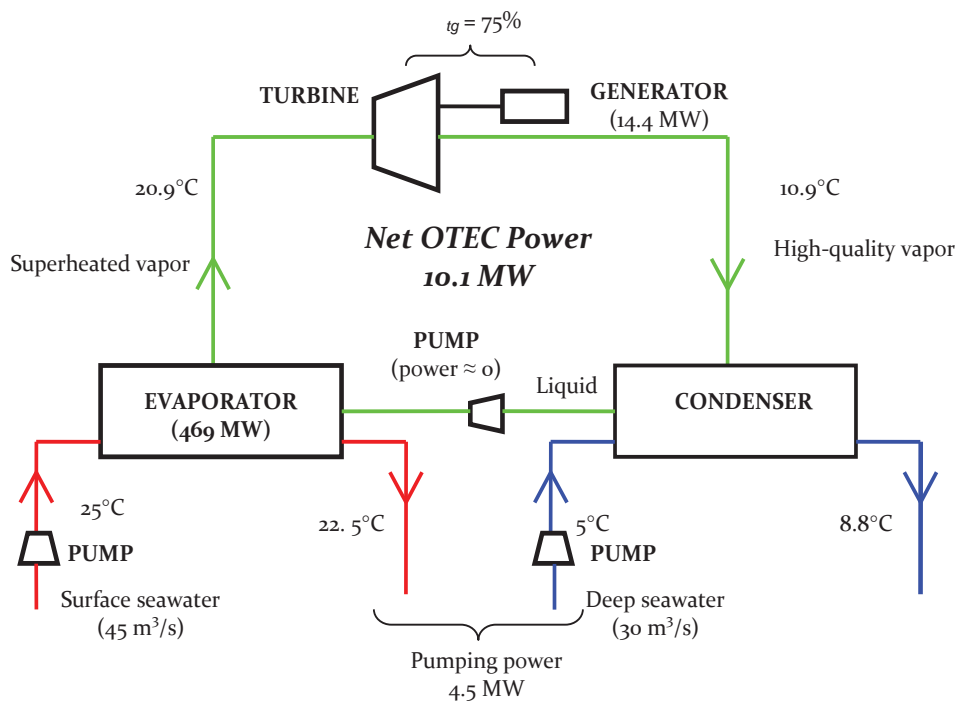

With a temperature separation of only about 10°C across the turbine, the thermodynamic efficiency of OTEC cycles is low. To utilize such a marginal thermal resource, large heat loads and efficient heat exchangers are required. This in turn necessitates relatively large seawater flow rates. Combined flow rate intensities of the order of 7m<sup>3</sup>/s per net megawatt (MW) of OTEC electricity are expected. Generally, more surface seawater would be used since it is more readily accessible. However, withdrawing large volumes of deep cold seawater from water depths of about 1,000m is difficult, as the history of early OTEC development shows. The design of cold water pipes for large OTEC plants still represents a technological challenge today. Pipe diameters in excess of 10m would likely be required for OTEC plants of 100MW. Attempts to use smaller conduits with higher pumping velocities are constrained by the need to limit pumping power losses. With typical OTEC designs, overall power losses typically represent 30% of the turbo-generator output.

Another consequence of small temperature differences across OTEC systems is that OTEC power production is sensitive to the stability of the thermal resource. Roughly speaking, turbine (gross power) output varies by about 10% for each 1°C change in seawater temperatures. As the margin for operational optimization is very limited, pumping power losses remain essentially unchanged. Hence, the sensitivity of net power output to environmental variability is even greater, at about 15% per 1°C change. Fortunately, most of the area deemed favorable for OTEC on an average basis, as illustrated in Figure 1, also turns out to have a stable thermal resource throughout the year. Caution should obviously be exercised when considering regions of greater seasonal temperature variability, like the Northern Gulf of Mexico. Such exceptions aside, OTEC stands out among renewable energy technologies as one of the few that could deliver baseload power.

Hence, OTEC systems require large components operating in deepwater offshore environments generally situated in tropical regions. Accordingly, OTEC plants are capital intensive. This has prevented so far the construction and deployment of commercial OTEC systems at sea, in potentially harsh and remote marine environments. In addition, the lack of modularity for key elements like the deep cold water pipe has made OTEC development quite difficult: unlike wind, wave or solar power technologies, for example, where large arrays of relatively small units are ultimately expected, the field testing of small OTEC plants necessitates the commitment of considerable resources if one aims to overcome scalability issues. Not surprisingly, OTEC technological development has been slow and rife with difficulties (Nihous and Gauthier, 2011).

## 2. History of OTEC

In the pioneering days of Georges Claude in the late 1920s and early 1930s, advances were made on a trial and error basis, since the field of ocean engineering had not matured (Claude, 1930; Claude, 1934). It can be argued that OTEC actually bankrupted the great and wealthy French inventor. Great strides were accomplished in the late 1970s through the early 1990s, when developed economies reacted to sharp oil price increases by initiating ambitious renewable energy development programs. Small floating OTEC plants were briefly tested in the U.S., such as 'Mini-OTEC', shown in Figure 3, and 'OTEC-1' (Macdonald, 1980). The Japanese also operated a land-based system in Nauru (Bjlkeman-Petterson, 2007). More details on these field experiments can be found in the literature (Avery and Wu, 1994). The riskiest component for OTEC plants is the large diameter deep cold seawater pipe that must be about one kilometer long. A very deliberate effort was made in the U.S. to establish the technical feasibility and scalability of this critical component (Vega and Nihous, 1988). To date, however, the largest OTEC plant ever run remains a land-based system temporarily built on the island of Hawaii in the early 1990s, as shown in Figure 4. It demonstrated the open-cycle OTEC configuration, where steam from warm seawater itself drives a large low-pressure turbine.

Gross (turbo-generator) power production reached 250kW, as most design and performance expectations were met, and a number of valuable lessons learned (Vega, 1995).

**Figure 3.** The ‘Mini-OTEC’ platform off of Hawaii in 1978



Photo credit: Luis Vega

**Figure 4.** Aerial view of an experimental open-cycle OTEC plant in Hawaii (early 1990s). The heat exchangers and turbine were enclosed inside the concrete cylindrical vacuum structure in the lower left corner

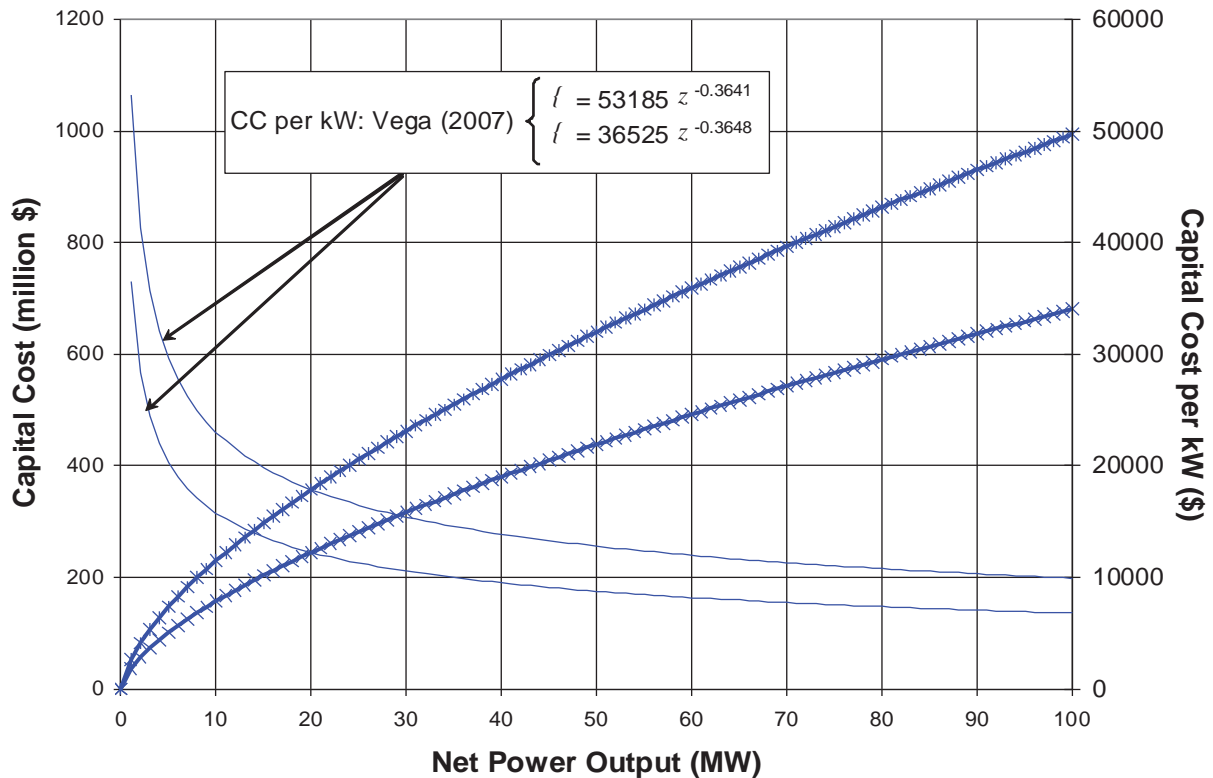

Photo credit: Luis Vega

### 3. The future of OTEC

Following the tests completed in the late 20<sup>th</sup> century, which still define the state-of-the-art today, the responsibility of OTEC technology development was implicitly handed to the private sector operating under open market mechanisms. As a consequence, OTEC has not only failed to achieve market penetration anywhere, but the necessary developmental steps that would *allow* commercial success have not been taken either. The relatively large size of OTEC components and the demands imposed by the offshore environment on equipment survival and power production logistics result in high projected capital costs. While substantial economies of scale are expected, the cost of OTEC electricity generation has remained economically unattractive for smaller systems. Investors so far have not deemed the risk of financing large OTEC projects acceptable without additional meaningful operational data. The dilemma faced by OTEC developers is well illustrated in Figure 5, based on a recent compilation of published updated OTEC design cost estimates (Vega, 2007). The amount of investment needed to deploy scalable floating pilot plants of 5 to 10MW is in the region of US\$200 million per plant.

**Figure 5.** Estimated OTEC plant capital costs (US\$) and costs per unit power produced (US\$/kW)



Hence, it is unlikely that private companies or consortia will undertake OTEC development on their own. Instead, the publicly funded efforts initiated decades ago in the wake of sharp oil price increases, but later abandoned when the economic and political contexts became less favorable for renewable energy development, have yet to be completed. The fact that global OTEC resources generally are situated between 30°N and 30°S also suggests that wealthy and technologically developed economies have little urgency promoting OTEC development. Yet, the same societal willpower is necessary that was successfully demonstrated in the past to launch ambitious and challenging programs involving, for example, the nuclear and space technologies.

Though cooperative frameworks are fraught with their own difficulties, a possible way to circumvent the reluctance of single stakeholders would be a coordinated initiative to advance the state-of-the-art of OTEC. With outstanding resources widespread across the region, it is reasonable to expect that such a partnership would involve Pacific Basin economies. It should start with a formal recognition of common needs and interests at the highest possible level, with a clear goal to design, deploy and operate OTEC pilot systems.

## References

- Avery, W.H. and C. Wu, Renewable Energy from the Ocean – A Guide to OTEC, in the Johns Hopkins University Applied Physics Laboratory Series in Science and Engineering (J.R. Apel ed.), Oxford University Press, New York, 1994, 446 p.
- Bjerkeman-Petterson, T., OTEC in Nauru. Two-part YouTube movie, 2007:  
[www.youtube.com/watch?v=\\_mGOcqofERM](http://www.youtube.com/watch?v=_mGOcqofERM)  
[www.youtube.com/watch?v=HWVWD80ENdM](http://www.youtube.com/watch?v=HWVWD80ENdM)
- Claude, G., Power from the tropical seas, *Mechanical Engineering*, 52(12), 1930, 1039-1044.
- Claude, G., L'état actuel de mes travaux sur l'énergie des mers, *Annaes da Academia Brasileira de Sciencias*, 6(4), 1934, 233-242 (in French).
- Locarnini, R.A., A. V. Mishonov, J. I. Antonov, T. P. Boyer and H. E. Garcia, *World Ocean Atlas 2005, Volume 1: Temperature*, S. Levitus, Ed., NOAA Atlas NESDIS 61, U.S. Government Printing Office, Washington, D.C., 2006, 182 p.
- Macdonald, B., Ocean Energy Launch 1980, Two-part YouTube movie, 1980:  
[www.youtube.com/watch?v=8aQXg5M5DiM](http://www.youtube.com/watch?v=8aQXg5M5DiM)  
[www.youtube.com/watch?v=9yRWNQ4OJDo](http://www.youtube.com/watch?v=9yRWNQ4OJDo)
- Nihous, G.C., A Preliminary Assessment of Ocean Thermal Energy Conversion (OTEC) Resources, *Journal of Energy Resources Technology*, 129(1), 2007, 10-17.
- Nihous, G.C., Mapping available Ocean Thermal Energy Conversion resources around the main Hawaiian Islands with state-of-the-art tools, *Journal of Renewable and Sustainable Energy*, 2, 043104, doi:10.1063/1.3463051, 2010, 9 p.
- Nihous, G.C. and M. Gauthier, Chapter 12: Ocean Thermal Energy Conversion : a historical perspective, in *Marine Renewable Energy Handbook*, B. Multon ed., ISTE, John Wiley & Sons, ISBN: 9781848213326, 2011, 367-401.
- Rajagopalan, K. and G.C. Nihous, Estimates of global Ocean Thermal Energy Conversion (OTEC) resources using an Ocean General Circulation Model, *Renewable Energy*, 50, 2013a, 532-540.
- Rajagopalan, K. and G.C. Nihous, An assessment of global Ocean Thermal Energy Conversion (OTEC) resources with a high-resolution Ocean General Circulation Model, *Journal of Energy Resources Technology*, in press, 2013b.
- Schlitzer, R., Ocean Data View, <http://odv.awi.de>, 2009
- Vega, L.A. and G.C. Nihous, Response of an OTEC Pipe Suspended from a Surface Vessel, *Proc. PACON '88 Conference*, Honolulu, Hawaii, July 1988, p. 5-15 to 5-23.
- Vega, L.A., The 210kW Open-Cycle OTEC Experimental Apparatus: Status Report, *Proc. Oceans '95 Conference*, San Diego, 1995, 6 p.
- Vega, L.A., The economics of Ocean Thermal Energy Conversion, *4<sup>th</sup> EnergyOcean Conference*, Turtle Bay Resort, Oahu, Hawaii, August 2007.

## Mechanical Energy: Wind, waves, current

**Marc Le Boulluec**, Research Engineer, IFREMER (French Research Institute for Exploitation of the Sea), France

### 1. From resource to energy conversion

Ocean energy is rightly considered as an enormous resource which could be used for human needs and activities. Beside ocean thermal energy, salinity gradient and biomass, mechanical marine renewable energy related to wind, waves and current is an area of scientific and technological research<sup>4</sup>.

Marine mechanical energy capture is the result of an integrated process starting from the resource evaluation, going through the design of energy converters and finally delivering energy to the grid. Assessments of resource and converters reliability and efficiency are key parameters which benefit from previously developed studies and procedures in the fields of marine transports, coastal engineering and the oil and gas industry.

Measurements at sea of wind, waves and currents are usually completed by numerical modeling in the context of meteorological prediction and operations at sea. Enhanced numerical simulation of sea states forced by wind and including interaction with bathymetry and currents is undergoing (The WISE Group 2007).

The design of fixed or floating bodies in the marine environment is supported by the great efforts made during the past decades in theoretical and numerical methods development for the oil and gas industry. Monitoring of the resource and environment, as well as the energy converters dynamics and production are essential.

The main target is to connect energy converters to the grid where they can deliver electrical energy. Alternatives include hydraulic energy and energy storage of various forms.

The development of mechanical marine renewable energy converters is facing technological barriers:

- Development of a large-scale and fine-mesh metocean (meteorology-oceanology) database
- Development of numerical tools on sea keeping and energy conversion
- Design of mooring systems
- Materials: reliability, fatigue, corrosion, bio-fouling, life cycle
- Operations at sea: deployment, inspection, maintenance, repair, dismantling
- Connection to the grid: underwater connectors, umbilical
- Energy storage: batteries, hydraulic, hydrogen?
- Evolution of standards from classification societies criteria
- Industry process: use of existing infrastructures and skills, upgrading.

---

<sup>4</sup> Bahaj, 2011

## 2. Resource and conversion principles

### 2.1. Wind energy

Wind energy is an intermittent resource which depends on the thermodynamics of the atmosphere and ocean-atmosphere exchanges. Due to the large number of observations by monitoring and from satellites, and to the increasing performances of numerical modeling, the short-term meteorological predictions are improving. Yearly statistics built on this large amount of data give a precise description of expected seasonal wind resources on large areas.

There is a need for more detailed information on the wind profiles and turbulences that the wind energy converters must cope with. Compared to the ground situation, wind at sea is most of the time stronger, less turbulent and more regular.

Conversion principles of wind energy are the most mature, based on the experience from terrestrial wind energy, horizontal axis wind turbines are the most developed but vertical axis wind turbine are also studied<sup>5</sup>. Considering the available area close to the coasts and the various bathymetries that can be encountered, floating concepts must be considered when the water depth is increasing.

At sea, fixed or floating offshore wind turbines are submitted to the marine environment, which induces additional loads such as wave loads and current effects. The foundation of fixed wind turbines and the moorings of floating wind turbines face new and different loads compared to the ground situation. In the case of floating structures, interaction of a wind turbine and its floating support induces particular dynamic response involving the damping and gyroscopic effects of the rotor, and dynamic stresses in the floater, the mast and the turbine composed of the nacelle and blades are specifically addressed<sup>6</sup>.

Supports technology are mostly derived from the oil and gas industry experience, including bottom-mounted structures with driven piles, suction base or gravity base structures and floating structures such as semi-submersibles, barges, tension leg platforms, spar buoys<sup>7</sup>. Today, an offshore wind turbine's rated power is 2 to 5MW, with a potential of up to 10MW.

### 2.2. Wave energy

Wave energy is an intermittent resource, related to the far-wind generation (swell which can propagate over oceans) and close-wind generation (wind seas). Waves are characterized by statistics and probability of the occurrence of wave spectra, and are recorded in wave atlas. The wave energy is traditionally defined by the average energy flux per front unit width. This value is proportionate to the square of the wave height and can reach 100kW/m in the most energetic areas such as south Patagonia and the Hawaiian islands. Around northern Europe this level is around 50 to 70kW/m.

Sea states are usually defined by their spectrum and several parameters including the waves' significant height, energy period and direction. For an accurate tune of the wave energy capture and design of the wave energy converters, a precise description of the sea states is needed, such as multiple superimposed spectra<sup>8</sup>. For a better control of the devices, time-domain information about the incoming waves should be required. Wave energy conversion principles are the most various and gave rise to many concepts<sup>9</sup>. Three main principles are considered: oscillating water columns,

---

<sup>5</sup> Breton, 2009 and Chen, 2011

<sup>6</sup> Lackner, 2011 and Lefebvre, 2012

<sup>7</sup> Rodier, 2010 and Sun, 2012

<sup>8</sup> Saulnier, 2011 and 2012

<sup>9</sup> Examples of wave energy conversion and power take-off estimates can be found in Babarit, 2012.

moving bodies and overtopping. Other principles use the flexibility of materials and their piezoelectric properties.

The wave energy converters are designed to operate around their natural periods and to stand stresses induced by the most energetic marine environments. These targets go against the common objectives and operating situation of the ocean vehicles (ships, oil and gas platforms) for which minimum stresses and responses are sought. Design of wave energy converters is then a compromise between efficiency and reliability in energy conversion, and survivability in extreme conditions.

Besides the action of waves, actions of current and wind must be taken into account in the design of wave energy converters in terms of energy production and structural strain. Today, the targeted rated power of wave energy converters is around 1MW per unit.

### **2.3. Tidal and current energy**

The tidal energy seems to be the first ocean energy used in history. Some fishing techniques and salt pans can be considered as based on tidal energy use. From a mechanical point of view, some old tidal mills using the potential energy of tides have been recorded in the 12<sup>th</sup> century in Brittany, France. The first industrial tidal plant was built in the 1960s in the same area, with ten turbines able to deliver a total of 240MW. The most recent development in tidal energy is the Sihwa tidal power plant in South Korea.

Compared to wind and waves, the tidal resource is predictable, the tidal height and current speed can be computed at a given place and time. Places suitable for kinetic current energy conversion can be selected from these first estimations, but more accurate studies must be done to evaluate the effects of the bathymetry, current profile and turbulence, and the waves and current interaction.

Based on the same basic principle as wind turbines, marine current turbines experience lowest fluid flow but with a much heavier fluid. The ratio of the specific masses of water to air is around 800, which means that the theoretical power of small-sized marine current turbines can be similar to the one of wind turbines. Loads induced on the foundations or moorings by the water flow need particular attention and original solutions<sup>10</sup>. Underwater operation of marine current turbines is made particularly difficult because of debris and particles in the water flow, possible collision with ships or drifting objects, marine growth, water tightness, wakes interaction and sediment transport<sup>11</sup>.

Today, the targeted power of marine current turbines is generally around 1MW per unit with a potential of 2MW.

### **2.4. Action of the environment and response of the MRE (marine renewable energy) converters**

The action of the environment on marine energy converters is particularly important and directly related to the available resource. The actions of wind, waves and currents are basically modeled by fluid mechanics and fluid structure interaction. The response can be assessed by three complementary approaches: numerical modeling, model testing, full scale observation and data from real-life-testing. The design of marine devices, and particularly ocean energy converters, is generally based on similar steps, with increasing size and complexity in model-testing in experimental tanks, then an intermediate scale at sea with energy production and finally a full-scale demonstrator at sea<sup>12</sup>.

<sup>10</sup> Johnstone, 2011

<sup>11</sup> Myers, 2012

<sup>12</sup> EquiMar, 2011



Besides individual aspects, the aggregations of tens of converters in farms induce interaction effects that must be carefully studied for an optimum energy capture<sup>13</sup>. Wakes effects associated to turbines, diffraction and radiation effects related to fixed and floating bodies, combination of moorings, are all theoretical and practical problems in the case of multiple converters interactions<sup>14</sup>.

### 3. Needs in term of research

#### 3.1. Seakeeping scaling effects

The assessment of MRE converters requires various trials at different scales. Seakeeping trials are run in tanks with simulation of combined waves, currents and wind if necessary. Scales should be of order  $\sim 1/10$  to  $1/25$ , and in any case  $>1/50$ . Most model-testing is based on the Froude scale, which is linked to the free surface gravity waves and a perfect fluid assumption. Differences between model-scale and full-scale behavior is a common issue in the experimental study of marine devices, which is mainly related to the viscosity of fluids as characterized by the Reynolds number and associated damping effects. In the case of marine energy devices, particular problems arise with air compressibility (in the case of oscillating water columns for instance), drag and torque of turbines, which depend on the Reynolds number and with Power Take-Off modeling.

There is a need for an “equivalent” conversion device at model-scale to properly model the Power Take-Off effects. Validation of numerical modeling towards model-scale tests enables “extrapolation” to full-scale. Analysis of data from full scale trials is then needed in order to more precisely assess the calibration of numerical models.

#### 3.2. Other laboratory trials

Tests of material in laboratory and marine environment are based on samples and some components at full scale. This includes the study of:

- Fatigue and protection against corrosion of metallic alloys;
- Evaluation of properties and ageing of composites and polymers;
- Characterization of synthetic lines;
- Protection against bio-fouling; and
- Bench-testing of electrical systems including performance in power conversion, water tightness of bearings and connectors.

#### 3.3. Sea trials

Large-scale testing (scale  $\sim 1/4$  to  $1/1$ ) can be run at sea in dedicated sites. At least ten sites are available all around Europe and five are under development in France. One of the most important is the EMEC test site in Orkney Islands, where both wave and tidal energy devices can be tested<sup>15</sup>. In the Pacific Ocean is the Hawaii National Marine Renewable Energy Center<sup>16</sup>, which enables the study at sea of wave energy and ocean thermal energy conversion (OTEC).

The tests sites generally include:

- Monitoring of the environment (waves, wind and current measurement);
- An electrical hub able to connect several marine energy devices to the grid;
- Ground-base facilities with monitoring of the electrical flux; and

<sup>13</sup> Madariaga, 2012

<sup>14</sup> Bahaj, 2011 and Myers, 2012

<sup>15</sup> <http://www.emec.org.uk>

<sup>16</sup> <http://hinmrec.hnei.hawaii.edu/nmrec-test-sites>

- Operational teams with divers and supply boats for deployment of moorings and prototypes, and for maintenance.

### **3.4. Environmental impacts**

Marine renewable energy converters impact their natural environment. The energy capture modifies the local flows. This seems less sensitive considering the offshore wind, but obviously current and waves around the energy converters and moreover farms of converters experience reduction in intensity. Interaction of structures and wakes as well as underwater mooring lines and cables with the seabed can induce erosion, sediment transport and modification of ecosystems. The presence of mechanical devices with rotating and oscillating components produce acoustic noise, electric engines and the electrical cables connecting the offshore converters to the ground-based grids induce electromagnetic flux. The impact of acoustic noise and electromagnetism on the environment, fauna and flora, still needs further investigation.

### **3.5. Societal impacts**

The marine environment, especially coastal areas is a multi-user area, involving marine activities such as navigation, fishing and recreation. Coastal populations are often reluctant to the installation of marine structures visible in the landscape. Installation of marine structures may face juridical obstacles, including considerations about the continental shelf and the exclusive economic zones.

### **3.6. Monitoring**

The evaluation of resource and monitoring of marine energy converters and their environmental impacts require particular instruments and techniques.

Particular needs emerge for the following topics:

- Wave and current interaction;
- Current profile and turbulence; and
- Current and waves fields measurements, including the use of Acoustic Doppler Current Profilers, high frequency radars, etc.

### **3.7. Collaborative networks**

In Europe, collaborative projects funded by the European Community (EquiMar<sup>17</sup>, Marinet<sup>18</sup>, etc.) or organizations (EERA<sup>19</sup>) contribute to upgrading the knowledge and reliability of marine renewable energy converters.

## **4. Conclusion**

The study and development of marine renewable energy conversion benefit from acquired knowledge in the fields of marine technology, ocean engineering, oil and gas industry, and electrical engineering. Both academic and technical disciplines are involved in the design process of marine renewable energy converters; for example:

- Physical oceanography, meteorology;
- Fluid mechanics and hydrodynamics;
- Materials and structures, chemistry;

<sup>17</sup> Equitable Testing and Evaluation of Marine Energy Extraction Devices in terms of Performance, Cost and Environmental Impact. The three-year EquiMar project was completed in April 2011. Important results from this project are protocols aimed at establishing rules for marine energy standards. They cover: resource assessment, environmental assessment, tank testing, sea trials, deployment and performance assessment of multi-megawatt device arrays, project assessment, market assessment. <http://www.equimar.org>

<sup>18</sup> Marine Renewables Infrastructure Network, <http://www.fp7-marinet.eu>

<sup>19</sup> European Energy Research Alliance, <http://www.eera-set.eu>

- Electrical engineering;
- Thermodynamics;
- Geotechnics;
- Acoustic; and
- Environmental and societal issues.

The industrial development of marine renewable energy conversion is then an exemplary subject for public - private partnership.

## References

- Babarit, A., J. Hals, M.J. Muliawan, A. Kurniawan, T. Moan and J. Krokstad, Numerical benchmarking study of a selection of wave energy converters, *Renewable Energy*, Volume 41, May 2012, Pages 44-63.
- Bahaj, A.S., Generating electricity from the oceans, *Renewable and Sustainable Energy Reviews*, Volume 15, Issue 7, September 2011, Pages 3399-3416.
- Breton, S.-P. and G. Moe, Status, plans and technologies for offshore wind turbines in Europe and North America, *Renewable Energy*, Volume 34, Issue 3, March 2009, Pages 646-654.
- Chen, L., F.L. Ponta and L.I. Lago, Perspectives on innovative concepts in wind-power generation, *Energy for Sustainable Development*, Volume 15, Issue 4, December 2011, Pages 398-410.
- Johnstone, C.M., The challenges to be addressed if tidal energy is to become economically viable, Proceedings of the Sixth International Conference on Asian and Pacific Coasts (APAC 2011). December 14 – 16, 2011, Hong Kong, China.
- Karimirad, M. and T. Moan T., A simplified method for coupled analysis of floating offshore wind turbines, *Marine Structures*, Volume 27, Issue 1, July 2012, Pages 45-63.
- Lackner, M. A. and M.A. Rotea M. A., Structural control of floating wind turbines, *Mechatronics*, Volume 21, Issue 4, June 2011, Pages 704-719.
- Lefebvre, S. and M. Collu, Preliminary design of a floating support structure for a 5MW offshore wind turbine, *Ocean Engineering*, Volume 40, February 2012, Pages 15-26.
- Madariaga, A., I. Martínez de Alegría, J.L. Martín, P. Eguía and E. Ceballos, Current facts about offshore wind farms, *Renewable and Sustainable Energy Reviews*, Volume 16, Issue 5, June 2012, Pages 3105-3116.
- Myers, L.E. and A.S. Bahaj, An experimental investigation simulating flow effects in first generation marine current energy converter arrays, *Renewable Energy*, Volume 37, Issue 1, January 2012, Pages 28-36.
- Roddier, D., Ch. Cermelli, A. Aubault and A. Weinstein, WindFloat: A floating foundation for offshore wind turbines, *Journal of Renewable and Sustainable Energy* 2, 033104, 2010.
- Saulnier, J-B., M. Prevosto and Ch. Maisondieu, Refinements of sea state statistics for marine renewables: A case study from simultaneous buoy measurements in Portugal, *Renewable Energy*, Volume 36, Issue 11, November 2011, Pages 2853-2865.
- Saulnier, J-B., Ch. Maisondieu, I. Ashton and G.H Smith, Refined sea state analysis from an array of four identical directional buoys deployed off the Northern Cornish coast (UK), *Applied Ocean Research*, Volume 37, August 2012, Pages 1-21.
- Sun, X., D. Huang D. and G. Wu, The current state of offshore wind energy technology development, *Energy*, Volume 41, Issue 1, May 2012, Pages 298-312.
- The WISE Group, L. Cavaleri, J.-H.G.M. Alves, F. Ardhuin, A. Babanin, M. Banner, K. Belibassakis, M. Benoit, M. Donelan, J. Groeneweg, T.H.C. Herbers, P. Hwang, P.A.E.M. Janssen, T. Janssen, I.V. Lavrenov, R. Magne, J. Monbaliu, M. Onorato, V. Polnikov, D. Resio, W.E. Rogers, A. Sheremet, J.

McKee Smith, H.L. Tolman, G. van Vledder, J. Wolf and I. Young, Wave modelling – The state of the art, *Progress In Oceanography*, Volume 75, Issue 4, December 2007, Pages 603-674.

## Development and Commercialization of the CETO Wave Technology

Tim Sawyer, Site Development Manager, Carnegie Wave Energy Limited, Australia

### Abstract

Carnegie Wave Energy Limited has been developing the CETO wave energy technology for more than ten years and at a cost of some A\$60 million. The technology has moved from initial concept, wave tank testing, to-scale in-ocean testing to commercial demonstration off the coast of Western Australia. In 2011, Carnegie Wave Energy successfully deployed and tested a single commercial-scale autonomous CETO unit off Garden Island near Perth, Western Australia. Following this test, EDF Energies Nouvelles and DCNS, with the support of A\$5 million of French Government funding, are now deploying an autonomous CETO Unit with a 10-metre diameter buoy off La Réunion Island in the Indian Ocean. The rollout of the CETO technology is now poised to proceed to a grid-connected, multi-unit array project at the Garden Island site in Western Australia, known as the 'Perth Wave Energy Project'. The project will produce renewable emission-free electricity to be purchased by the Australian Department of Defence. The project is supported by grant-funding from the Australian and Western Australia governments. Carnegie is also advancing a pipeline of commercial projects to enable roll-out of the CETO technology in key international target markets.

### 1. Introduction

Carnegie Wave Energy Limited ('Carnegie') is the ASX-listed owner and developer of the CETO wave energy technology that converts ocean swell into zero-emission, renewable power and directly desalinated water.

Figure 1. CETO technology schematic



CETO is a unique, fully submerged, pump-based technology whereby a submerged buoy moves with the ocean's waves, 1–2 meters below the surface of the ocean, driving a seabed-mounted pump. As the buoy oscillates with wave motion, the pump propels high-pressure, water-based fluid ashore via a subsea pipeline. This high-pressure fluid then powers a hydroelectric turbine to generate zero-

emission, renewable electricity. The same fluid is then returned to the offshore CETO units through a second pipeline, creating a closed loop (Figure 1).

The CETO technology has been under development for over ten years, from initial concept to demonstration of a single commercial-scale CETO unit in the open ocean in 2011 off Garden Island, Western Australia. Carnegie is now focused on the design, installation and operation of a commercial CETO power generation plant delivering electricity to the power grid, known as the Perth Wave Energy Project.

## 2. Garden Island, Autonomous Unit

In 2011, a third-generation, 80kW capacity CETO unit was installed in 25-meter depth in an area known as the Sepia Depression, west of Garden Island in Western Australia (Figure 2). The unit is operated autonomously via a seabed mounted hydraulic module immediately adjacent to the unit foundation. The hydraulic module imitated a future pipeline and onshore power plant through the use of proportional control valves, a heat exchanger for energy dissipation and an industrial controller.

*Figure 2. CETO unit off Garden Island, Western Australia*



The primary objective of the single unit deployment was to validate numerical models using measured data. The heavily instrumented CETO unit and hydraulic module were subjected to waves of up to 4.6 meters in height. Data were transmitted back to shore using cellular networks in near real-time for analysis. These data were provided to Frazer-Nash Consultancy, who independently verified the results and validated the numerical model used for the design. The future design work has leveraged heavily on these numerical models and the confidence gained from the validation process.

## 3. Garden Island, Perth Wave Energy Project

The Perth Wave Energy Project (PWEP) is a grid-connected, multi-unit CETO array project located off Garden Island, Western Australia, home to Australia's largest naval base, HMAS Stirling. This project will be the first demonstration of a complete grid-connected, multiple-unit, commercial-scale CETO

system anywhere in the world. The project will also deliver Carnegie its first power sales revenues through the sale of the electricity to the Australian Department of Defence. The project is expected to commence construction in 2013 and deliver electricity in 2014.

As a demonstration project, the main purpose of the project is to demonstrate the systems engineering, detailed design, manufacture, construction, deployment, operation and routine maintenance of a CETO wave energy system and to produce and sell electricity to a credible customer via a utility compliant grid connection.

The project is a key step in Carnegie's commercialization pathway for CETO and will be the company's primary focus through to its commissioning and operation. Successful completion of the project will provide Carnegie with the confidence to roll out targeted commercial project opportunities in attractive wave power markets globally.

### **3.1. Objectives**

The key objectives of the project are to demonstrate the technical and commercial viability of the CETO technology and learn from the experience of deploying and operating the complete CETO system; specifically:

- Demonstration of the largest capacity CETO unit developed to date;
- The production of utility-quality electricity by generating and exporting power to the grid for a sustained period;
- Verification of Carnegie's computational CETO system modeling against measured system performance;
- Understanding the interaction of multiple commercial-scale CETO units operating in an array;
- Confirming the feasibility of the deployment, operation and recovery of the Project's major elements including pipeline, CETO units and foundations;
- Monitoring and understanding the potential environmental impacts to demonstrate and verify the technology's minimal impact and to optimize system design to reduce impact further still; and
- Demonstration of Carnegie's ability to plan, resource and execute a commercial-scale CETO project.

### **3.2. Technology**

The PWEF will incorporate 5<sup>th</sup> generation CETO technology which has higher capacity and improved conversion efficiency than previous generations (Figure 3). The larger Buoyant Actuator (BA) offers significantly higher power output than the autonomous unit deployed at the same site. More advanced tuning of the unit to the wave climate offers a boost in conversion efficiency. In addition, Carnegie has developed a more efficient unit deployment methodology leveraging oil and gas style "quick connect" technology which will significantly decrease installation times.

The offshore array of CETO units connect to a central hydraulic manifold that channels the pressurized fluid into two pipelines, one high-pressure, one low-pressure. The offshore hydraulic plant includes various valves, including check valves, remotely actuated isolation valves and safety relief valves. Signals from over 200 sensors are aggregated at the manifold for transmission to shore via communication cables.

Once onshore, the pipelines enter the power plant where the hydraulic energy is converted to electrical energy. Special algorithms have been developed to balance the pressure control requirements with the requirements for smooth electrical output of the plant.

**Figure 3.** 3D render of 5th generation CETO unit



### **3.3. Funding**

Carnegie has secured approximately 50% government funding through a combination of Western Australian State Government funding and Australian Federal Government funding. The balance of project funds will be sourced by Carnegie.

In 2009, Carnegie secured a A\$12.5 million grant funding in from the Government of Western Australia's Low Emissions Energy Development (LEED) Program. The LEED funding covered both the single CETO 3 unit in 2011, as well as the Project itself. In May 2012, the Project was awarded a A\$9.9 million Australian Federal Government grant from the Australian Renewable Energy Agency's Emerging Renewables Program. As the Government grants are milestone-based, retrospective funding, Carnegie will be reimbursed for the Government's share of expenditure once it can demonstrate satisfactory completion of each milestone.

### **3.4. License and power supply**

In July 2012, Carnegie signed a formal license agreement for the use of Commonwealth lands for the Project's onshore facility located on Garden Island. Carnegie has also signed formal grid connection and power supply agreements with the Department of Defence, who will purchase all of the power produced by the Project. These landmark agreements not only demonstrate Defence's support for the CETO technology and the Project, but will also provide Carnegie with its first power sales revenue. These agreements were the culmination of three years of discussion, due diligence and negotiation with the Department of Defence, following on from signing a Memorandum of Understanding in 2009.

### **3.5. Site details**

The Project site is located off Garden Island in Western Australia (Figure 4). The onshore components of the Project, comprised of the onshore powerhouse and the connection to the grid,



will be located on Commonwealth (Defence) land in a disused, pre-disturbed quarry on the south west side of Garden Island. The offshore components, including pipelines and the CETO units, will be located in 25-meter depth of water, approximately 3km offshore from the powerhouse (Figure 4).

**Figure 4.** PWEP site map

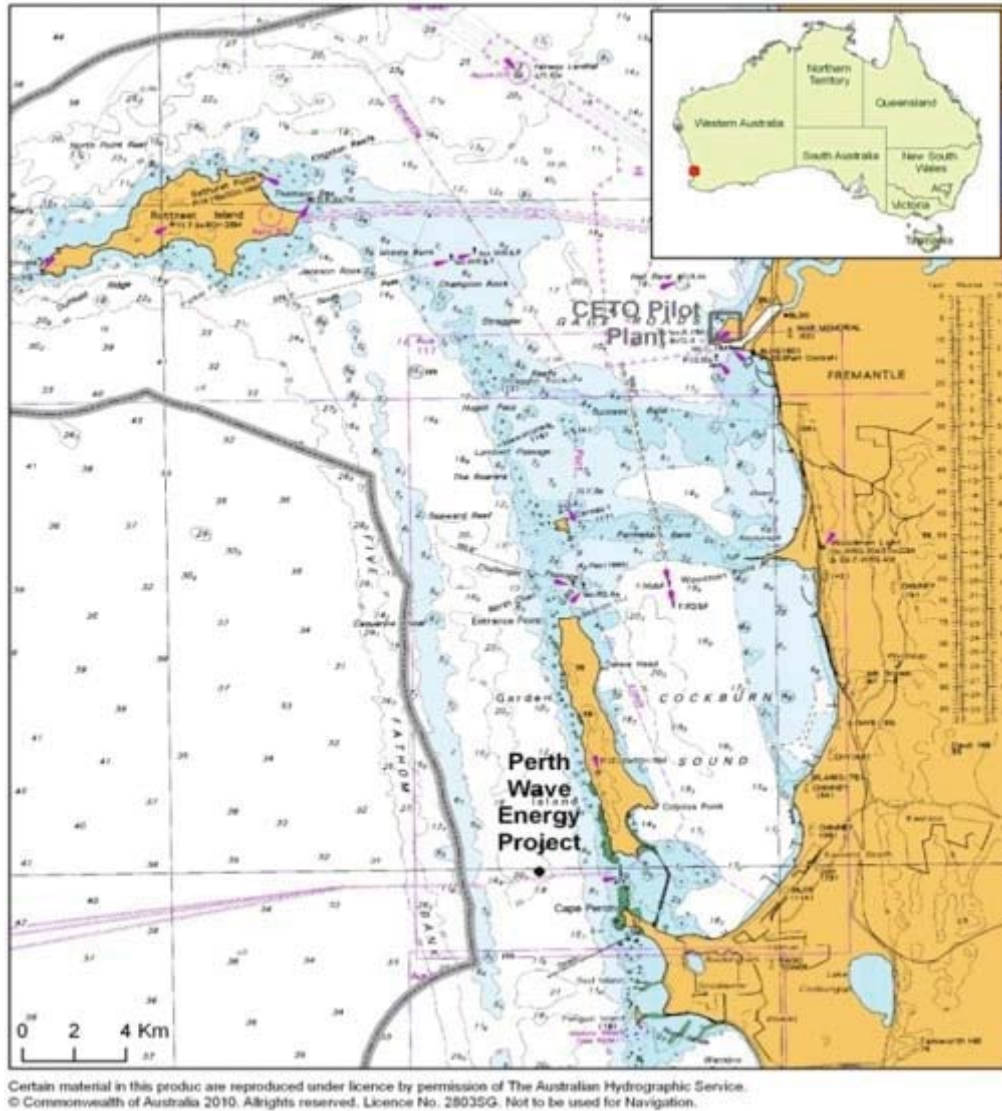

#### 4. Reunion Island Project

Carnegie is working with the first licensee of the CETO technology, EDF Energies Nouvelles (EDF-EN) to deploy a CETO unit on the French department of Reunion Island. This single, CETO 4 unit deployment has been funded by a French Government grant of A\$5 million and EDF EN, and is the first stage of a larger CETO Project planned to be 15MW. The single CETO unit manufacture and installation is being managed by French marine defense contractor DCNS.

The CETO 4 unit has been manufactured and delivered on site, pre-deployment testing has been completed and the subsea energy management system has been successfully deployed (Figure 5). The rest of the CETO unit is awaiting a period of sufficiently calm weather to allow deployment to be completed. DCNS is using a deployment methodology that is similar to the methodology Carnegie used for the single CETO 3 unit test at Garden Island in 2011.

**Figure 5.** *Tow-out of the subsea energy management system at Reunion Island*



## 5. Commercial project pipeline

Carnegie has been developing a national and international portfolio of sites, in parallel to the technology development, which will enable the commercial roll-out of CETO projects. Project development is focused on sites that provide a strong wave resource and meet site specific requirements such as suitable seabed conditions, minimal environmental impact and sufficient supply chain. Carnegie is currently focused on countries which have in place strong support mechanisms, such as capital project grants, marine energy targets and feed-in tariffs. These include Europe, Australia and, potentially, Chilean projects. In addition, Carnegie is developing projects in remote island nations where there is strong demand for clean power and desalinated water, combined with high power tariffs and energy and water security needs. Examples include Bermuda, French Polynesia, Réunion Island, Canary Islands, Maldives, and throughout the Asia-Pacific region.

### Acknowledgements

The Perth Wave Energy Project received funding from the Australian Government as part of the Australian Centre for Renewable Energy’s Emerging Renewables Program.

The Perth Wave Energy Project received funding from the Government of Western Australia as part of the Low Emissions Energy Development (LEED) Program.

The Réunion Island Project received funding from the French Government.

## Research on Tidal Power Generation in the National Taiwan Ocean University

Cheng-Han Tsai, Professor, National Taiwan Ocean University (NTOU), Keelung

### 1. Introduction

Crude oil prices are hovering near or above US\$100 per barrel and alternative energy sources have become an important subject matter for the energy security across all nations. In addition to energy prices, concerns about global changes and the safety of nuclear power, clean and renewable energy have gained tremendous momentum in the search of alternative energy sources. Renewable Energy Policy Network for the 21<sup>st</sup> Century (2011) pointed out that 3% of the global electricity generation in 2010 used non-hydro renewable sources, such as solar, wind, geothermal and biomass. Moreover, according to the energy review of British Petroleum (BP), the world energy consumption in the form of renewable energy has increased by 15.5% in 2010 over the previous year (British Petroleum, 2011). This shows that renewable energy is becoming an important energy source.

Oceans store a vast amount of renewable energy, which includes energy from ocean temperature differences, wave, current, tidal stream and tide. Since ocean energy technology is still in its infantile stage of development, only a few ocean energy systems reached commercial scale. However, in the recent years, electricity production converted from ocean energy has attained significant developments and interests.

Ocean tides are the result of gravitational pull of the moon and the sun on Earth. Most areas show two rises and falls in one day. In places where there is a large difference in the levels of high and low tides, this vertical difference, called tidal range, can be used to generate electricity, much like the conventional hydropower generation. On the other hand, the propagation of tides also produces a horizontal current, called tidal current or tidal stream. In some coastal locations, the tidal stream can be strong enough to generate electricity. The National Taiwan Ocean University has been granted a three-year (2010-2012) pilot project by the national energy program (NSTPE, 2012) on the subject of tidal stream energy conversion. The project is a collaborating effort of nine experts in oceanography and ship propulsion in our university. It is the purpose of this article to present the framework of the project and some results.

### 2. A pilot project

The present project focuses on five inter-related subjects, including numerical simulation of tidal current, *in situ* current measurement, tidal current assessment using satellite remote sensing, turbine blade design and development of a 3kW underwater tidal stream power generator, and assessment of natural forces from typhoon wind and waves on the generator's structure. The National Taiwan Ocean University assembled a team of nine researchers to work on this project. The basic requirement for the project is to locate a suitable location where there is strong tidal current, so that the tidal power generator can be tested after its completion.

It is well known that the tidal current on the northern coast of Keelung is stronger than that of other coasts of the island. The coastal water between the Keelung Harbor and Keelung Island (Figure 1) is of particular interest, since there is an underwater ridge south of the Keelung Island, called Keelung Sill. The water depth at the location surrounding the sill is about 60m, and the depth of the sill ranges between 5m and 40m. The peak tidal current speed at the coastal water off the northern part

of the island is around 1-3 knots (0.5~1.5 m/s). But when the tidal current approaches the Keelung Sill, it can go up to more than 5 knots, due to the contraction of the flow section. This makes the area on Keelung Sill a potential site for tidal current energy studies, and this is the location where we test our tidal power generator.

**Figure 1.** Bottom bathymetry near the Keelung Sill. NTOU is the National Taiwan Ocean University.

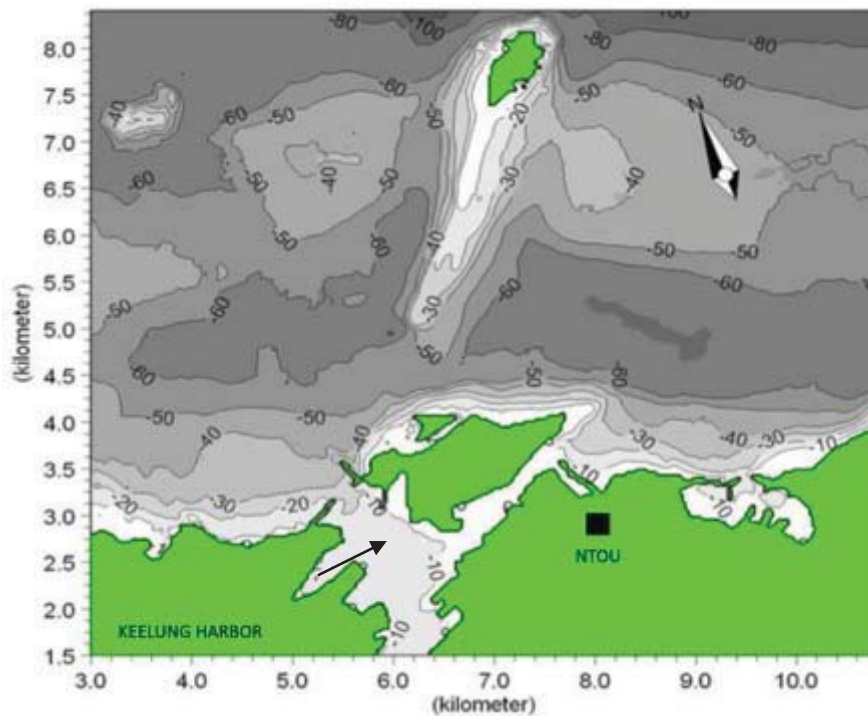

In our field measurements, we have collected seven one-month tidal current information using Acoustic Doppler Velocity Profiler (ADCP), which measures current based on Doppler principle, at various stations on the Sill. The measurement stations located at depths of 5m, 6m, 10m, 15m, 20m, and 25m, respectively. Our results indicated that the current here was clearly dominant by tidal current with flood tide in the northwest direction and ebb southeast direction. Among these stations, the 6m and 25m sites had the highest velocity, whose peak speed was 2.7m/s. The peak speeds measured at 20m stations was 2.4m/s, while the 10m and 5m site were about 2.2m/s. The mean speed for these stations was about 1.0-1.3m/s. We also found that the percentages of speed higher than 1 m/s were 31%, 57%, 47%, and 48%, for the 5m, 6m, 20m, and 25m stations, respectively. Our *in situ* current measurements suggested that the 6m deep station is a good location for testing our tidal stream generator.

In our numerical simulation study, we have been able to correctly simulate the tidal current in the area on the Keelung Sill. This simulation will help us predict the tidal current speed and direction of our tidal power station site. Figure 2 shows one of our simulation results. The arrows indicate the speed and direction of the tidal current. As can be seen, the current speeds on top of the Sill are particularly strong.

One of the major tasks of this study is the design of turbine blades and a 3kW power generation unit. The objective of the turbine blades design is to find an optimal configuration -camber and pitch- for the blades to provide maximal power output for the operational current speed. For this, the propeller lifting line theory was used. From our calculations, it was found that the three-bladed turbine is more efficient than the two-bladed one, and an 80cm three-bladed turbine has its

maximum efficiency of 45% at 6.2rps (revolutions per second). This maximum efficiency agrees with the results found in other similar turbines (Bahaj et al., 2007).

**Figure 2.** Tidal current simulation for the Keelung Sill Site

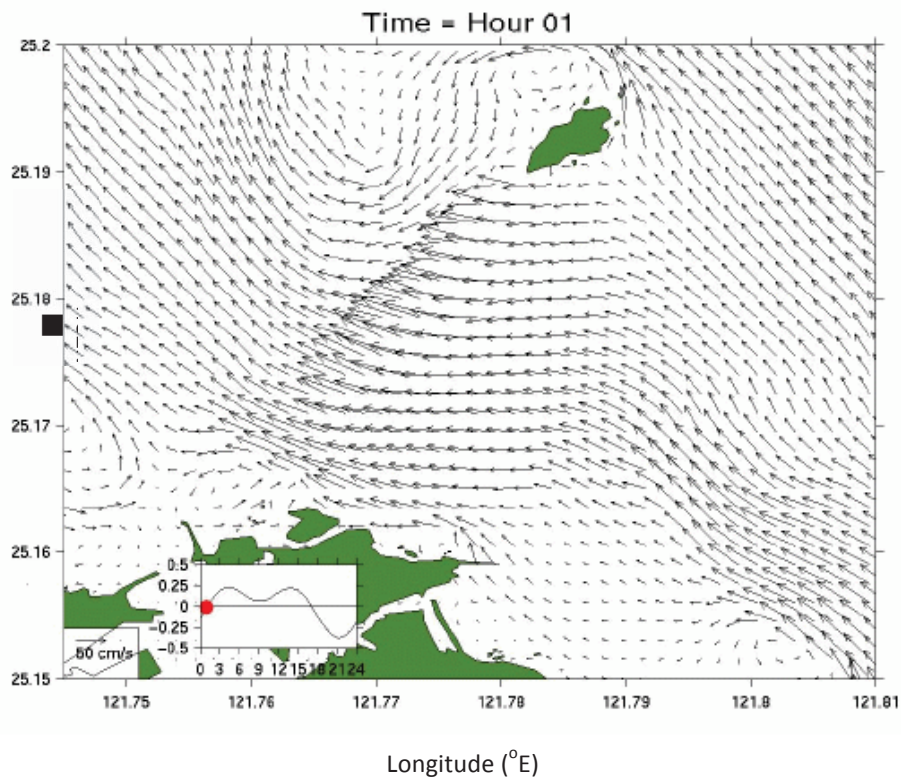

Besides the turbine, the power generation unit consists of a gear box, water tight underwater generator manufactured by Siemens, an outer-casing and a quad-pod understructure allowing the generation unit to sit on the sea bottom. Since the tidal current changes direction with time, the turbine should be able to face into the current to maintain its maximum efficiency. The unit is attached with tailfins so that it turns with the current passively, without any active controls to change the turbine direction. The casing unit is supported by a central shaft, which is mounted on the quad-pod. In the central shaft circular, electrical contacts allow the electrical output to be connected to cables at all times, while the upper casing unit turns with the tidal current. Figure 3 shows the completed tidal stream power unit. This unit has been tested in the cavitation tunnel of the National Taiwan Ocean University for its water tightness and electric power output. This unit has also been successfully tested at the Keelung Sill site in the summer of 2012 (Figure 4).

**Figure 3.** Tidal power unit being tested in the cavitation tunnel



**Figure 4.** Sea trial of the tidal unit at the Keelung Sill site in the summer of 2012



Tidal stream energy is not the only marine current energy that can be used for electricity generation. On the east coast of the island, there is a strong ocean current, called Kuroshio, which is about 100km wide and about 700m deep with an average speed of about 1m/s. This current is the second largest ocean current in the world after the Gulf Stream. The Kuroshio has enormous amount of energy. Our effort in developing a tidal stream power unit can assist the development of a more sophisticated unit to tap into the Kuroshio energy.

## References

BP (British Petroleum), *Statistical Review of World Energy 2012*

<http://www.bp.com/sectionbodycopy.do?categoryId=7500&contentId=7068481>

NSTPE (National Science and Technology Program-Energy) 2012

<http://nstpe.ntu.edu.tw/introduction.php?l=e>

Bahaj, A.S., A.F. Molland, J.R. Chaplin and W.M.J. Batten, Power and thrust measurements of marine current turbines under various hydrodynamic flow conditions in a cavitation tunnel and a towing tank, *Renewable Energy*, 32, 2007, pp 407-426.

## The Exploration and Utilization of Marine Energy in China

**Wu Zhenglong**, Vice-Chair, China National Committee for Pacific Economic Cooperation, Beijing, China

### 1. Introduction

As a massive source of clean and renewable energy, the marine energy drew extensive attention from coastal economies in the 1970s. Since the beginning of the new century, however, fossil energy, such as petroleum and coal, have become increasingly depleted, global climate has changed for the worse and the need to save energy and reduce emissions have become more urgent. The international community has come to understand that a country or an economy can only realize green growth in the 21<sup>st</sup> century through the development of clean energy.

Marine energy refers to all kinds of natural energy resources embedded in the sea or derived from the sea. It mainly includes tidal energy, wave energy, current energy, thermal gradient energy, salinity gradient energy, sea biomass energy, and offshore wind energy.

Coastal and island countries or territories worldwide are casting their eyes toward marine energy and stress the strategic importance of marine energy in their future energy development. The Chinese Government took the initiative to announce the goal of greenhouse gas (GHG) emission control on November 25<sup>th</sup>, 2009, committing itself to reducing the emission of CO<sub>2</sub> by 40% to 50% per unit of GDP against the 2005 level, and taking it as a binding indicator in the medium- to long-term national economic and social development plans.

The exploitation of marine energy is of strategic significance to China. On April 1<sup>st</sup>, 2010, the “PRC Renewable Energy Law” was enacted in China. The adoption of this law marked a new historical period in China's exploration and utilization of renewable energy. As a part of renewable energy, marine energy has become one of the foci of the renewable energy development. The strategy of developing marine energy was reiterated in the 12th Five-Year Plan of the National Development and several other development programs.

It is estimated that China's theoretical installation capacity of offshore marine energy is over 2,750GW, three times the total installation capacity of electricity in 2009. The exploration and utilization of marine energy will mitigate the energy shortage in the coastal and island areas of China effectively. Therefore, marine energy is of strategic importance for optimizing energy structure, developing clean energy, dealing with climate change, and promoting a low carbon economy.

### 2. China's potential for marine energy

Marine energy offers great potential for China. As a big ocean economy with a coastline of 18,000 kilometers, with more than 6,900 islands over 500 square meters in area, and with nearly 200 gulfs and estuaries, the marine energy reserve is rich and ensures a good prospect for exploration and utilization.

The total capacity of developable tidal energy is approximately 22GW, mainly distributed in the coastal areas of Fujian Province and Zhejiang Province. Places like Qiantangjiang River Estuary and

Leqing Bay of the Zhejiang Province, and Sandu Bay and Luyuan Bay of the Fujian Province feature an average tidal range of four to five meters, with the maximum tidal range being 7 to 8.5 meters. With over 130 waterways and navigation gates, China tops the world in current energy potential, with a theoretical annual average capacity of 14GW. Zhejiang Province accounts for over half of the current energy reserve, with 37 waterways in its coastal area. Fujian and Liaoning Provinces take a share of 42% of the total capacity of China.

The total developable capacity of wave energy is about 13GW. With relatively weak offshore winds, China's power density of wave energy is relatively low with an average capacity of two to seven kilowatts per meter. However, with a vast marine area, there are many regions that have potential for development. The coastal areas of Zhjiang, Fujian and Guangdong provinces account for over 40% of the capacity, while Shandong Province accounts for over 10%.

The thermal gradient energy reserves surpass all the other types of marine energy sources with a potential capacity of 1,300GW. The South China Sea waters present the richest reserves with the highest power density of thermal gradient energy, where the temperature difference between the surface water and deep water registers between 20 and 24 degrees Celsius.

China also boasts rich offshore wind and biomass energy. The potential marine wind energy accounts for 450GW, three times the land wind energy, with Fujian, Jiangsu and Shandong provinces endowed with the richest marine wind energy. China has a large number of oil-rich algae species suitable for development of biomass energy.

Generally speaking, China has rich current and thermal gradient energy, and leads the world in power density. China stands at mid-level in terms of tidal energy reserves. The tidal energy is highly valuable for development. The offshore wind energy and marine biomass energy present great potential for development.

### **3. China's efforts in marine energy development**

China started to develop marine energy quite early and has accumulated considerable technological knowhow for the exploration and utilization of the marine energy. In the 1960s, China conducted a survey of marine energy resources, started to build tidal power stations, and gradually developed the technologies for the exploration and utilization of wave energy, tidal energy, thermal gradient energy, and salinity gradient energy.

China has built the largest number of tidal power stations in the world. Nearly 50 tidal stations were built between the 1950s and the 1970s. However, by the 1980s only eight stations were generating electricity normally. The Jiangxia Station in Zhejiang Province was the largest tidal station of China. It used to be the third largest in the world, albeit only one seventieth of the Rance tidal power station of France in terms of installation capacity. Despite the gap between the designed capacity and the actual performance, the Jiangxia Station turned out to be a success as it provided a wide range of technologies for China to build other tidal power stations as well as valuable knowhow in operation and management. In fact, there are now over 400 sites that are viable for building tidal power stations in China.

Since the 1970s, China has been engaged in the research of wave energy. Since the 1980s, rapid development has been achieved. A series of invention patents and scientific and technological achievements have been claimed in the area of wave power generation such as the 40watt buoy wave power generation device and the 10watt wave power generation device for navigation lights.



In fact, this technology has been commercialized with several hundred such devices produced and applied to buoy navigation lights. For experimental purposes, China has also built and operated a 100kW oscillating water column wave power plant in Shanwei, Guangdong province and a 30kW oscillating wave power station in Daguandao, Shandong province.

Recently, an ocean wind farm with an installation capacity of 102MW has been built along the Shanghai East Sea Bridge, composing thirty-four 3MW wind turbines. This is the first ocean wind farm in China, as well as in Asia.

Given the endowment of China's marine energy and the technological feasibility, China needs to focus on the industrialization of the power generation equipment at the level of 100kW, the development of tidal and current power stations at the 10MW level, and the research in the development of thermal gradient energy. In the mid- to long-term, more efforts should be made to develop comprehensive marine-borne systems supported by thermal gradient power stations at the 10MW level and mid- to large-scale ocean bio-farms.

#### **4. China's policy for marine energy development**

In recent years, China has taken measures to support the exploration and utilization of marine energy in areas of research, application and management. For instance:

- R&D and demonstration of the major marine energy technologies were listed as the key items in the Scientific and Technological Support Plan of the 11<sup>th</sup> Five-Year Plan, including projects such as 100kW buoy wave power plant, and 100kW oscillating wave power plant.
- Special programs were also set up to cover the marine energy survey and evaluation, in which a general on-site prospecting and assessment of the marine energy reserves and developable capacity was conducted. A special project was launched to build an independent power plant on near-shore islands as a demonstration by making complementary use of the energy resources such as wave energy, solar energy and island wind energy.
- In the National 863 Program, several projects were initiated to support the basic studies of marine energy and the development of key technologies for the power generation facilities. The very purpose of these studies is to substantially enhance China's innovation capacity and provide a solid base for the industrialization of ocean power generation.

It is essential to create a suitable environment for the development of marine energy. In line with the national strategy of the sustainable energy development, energy conservation and emission reduction, China is drafting the "Special Plan for the Development of Renewable Marine Energy". Having in mind the technological gap in the development of marine energy between China and other economies, China will step up international cooperation and independent innovation in exploring and utilizing marine energy, make more efforts to surmount the bottlenecks for the use of marine energy through experimental and demonstrative projects. China will initiate and improve the relevant policies and the system of the public utility, facilitate access to power on the remote islands through enforcement of the "Law on Island Protection", develop the technologies and the industry of ocean sustainable energy, improve the R&D capacity and the level of industrialization, and enhance the ability to develop and use marine energy on a large scale.

## 5. Outlook

It is estimated that by 2015, China will catch up to the level of the advanced economies at the turn of this century in terms of general capacity of marine energy development and utilization. China will be able to:

- Acquire a substantial capacity of demonstrating and applying the ocean power generation systems and reach the level of practical application for the marine energy development technology;
- Grasp and localize gradually the core technologies of offshore wind power generation for scale production;
- Overcome key technological barriers for current power generation;
- Develop wave energy technologies suitable to China's features;
- Make greater efforts to study the comprehensive use of thermal gradient energy; and
- Beef up studies on ocean biomass energy technologies with applicable prospects.

China will establish a supporting system for the development of renewable marine energy technologies, sort out the reserves and the distribution of the near-shore renewable marine energy, set up a platform as a public utility for comprehensive tests and experiments. China will promote the industrialization of marine energy in a substantial way and build up a considerable number of enterprises in this area. An industrial chain of R&D, equipment manufacturing, project engineering, and operation and management will be fledging. At the same time, China will develop a compatible soft environment for the development of marine energy. It will consist of a standardized system, regulations and mechanisms on the management of marine energy.

## References

China New Energy website, <http://www.newenergy.org.cn>

China New Energy and Renewable Energy Yearbook

Sun, Jingya, Reflection on the Legal Institutional Building for the Development of Marine Energy, *Legal System and Society*, Vol. 25, Dec. 2010.

Xiao, Hanqiang et al, Thinking on Strategy of Developing China's Ocean New Energy Resources, in Proceedings of the 12th China Association of Science and Technology Annual Meeting, Nov. 1, 2011.

Xu, Mingding, Planning the New Energy Development Standing on a New Historical Point, *Electricity and Energy*, No. 1, Vol. 1, January 2011.

## Integrating the Many Sources of Renewable Energy into Urban Electricity Networks: An operator's point of view on smart grids

**Nicolas Renard**, Advisor to the Chairman & CEO of Veolia Environment, Paris, France

### Abstract

*There is an unending search for energy. Sea is the new frontier to get the energy we need. Solutions to solve our energy problems lie partly in the sea. The 20<sup>th</sup> century was the century of oil. The 21<sup>st</sup> will probably be one of hybrids: hybrid energy sources, hybrid roles of utility subscribers - as either energy consumers or producers. However, it is not sufficient to diversify sources of energy to attain sustainable growth. We must also reinvent electricity networks. Most of the major PECC economies have launched smart grid projects in order to progressively bring their electricity grids from the 20<sup>th</sup> to the 21<sup>st</sup> century. We are entering a new era of energy transition. Will we successfully manage all these hybrids and new grids? Smart grids may be the solution.*

### 1. Change in energy, change in power grid

Classical grids present several shortcomings:

- Line losses amount to between 7% and 16% of the power produced.
- Current grids do not support the massive deployment of many decentralized sources of power production.
- Existing transmission grids are not designed to accommodate renewable energy sources (intermittent and low production capacity) and the needs of an evermore technology-hungry society. For instance, the American grid was designed more than half a century ago. And the increase of intermittent energy sources (over 20% to 30% of the energy mix) makes the grid more unstable. Wind turbine systems in particular, cause disruptions when they stop operating because of heavy winds which lead to disconnection from the grid.
- We observe many power failures. This global phenomenon is mainly due to saturation of networks, undersized in relation to demand. Many American and Asian cities are suffering outages; the biggest failure occurred in Indonesia and affected 100 million people.

#### **1.1. There is a need for new tools to properly integrate a mosaic of energy sources**

Users will be more and more producers of power for their own needs, by means of micro-wind turbines, photovoltaic solar panels, etc. They will resell their surplus production or their voluntarily reduced consumption to the utility.

We need an “energy web” capable of absorbing all kinds of energy sources and which can redistribute them according to the varying needs. This implies that future architecture of the grid should be more flexible and modular. New grids should easily combine predictable and unpredictable sources of energy, power generators with opposite capacity production, from domestic solar panels to nuclear plants.

In the US, Japan or France, the former challenge was to integrate very high-capacity nuclear production plants into the power grid. Today's challenge is to integrate many intermittent, low-capacity and scattered sources of production into the grid. In order to optimize this multi-source/multi-use network, a smart management system has to be implemented.

### **1.2. Moving from a “one-way grid” to a “multi-way grid”**

A smart grid is a revolution which transforms both sides of network - electricity production and electricity consumption - and also the system itself.

A smart grid is a communicating grid. Its components are linked not just physically, through electric lines, but also virtually through meters and communicating devices. The physical power grid is paired with a communications network. A smart grid uses the latest ICTs to collect and manage real-time production and consumption. By providing access to information, it makes the interactivity between end-users and the grid possible.

Smart grids are tools for better controlling demand and managing peak periods, through voluntary consumption reduction:

- The offloading policy has already been successfully applied. California has set up offloads mechanisms for energy suppliers. It is cheaper for them to encourage their customers to save energy than to build new power production plants. However, this approach is effective because the price of kWh is higher in California.
- According to the International Energy Agency (IEA), smart grids could limit the need for the world to increase power production by between 13% and 24% to cope with peak-period needs and limit the emission of 2 gigatons of CO<sub>2</sub> each year.

### **1.3. Other major issues are also at stake with smart grids**

First, the deployment of electric vehicles. This move will sharply boost demand for power. Electric vehicles will impose constraints on grids and affect the economic equation. The main risk will involve recharging points at the end of the day. Smart charging technologies and recharging batteries at night should prevent spikes in demand. But electric vehicles are also a potential opportunity. The batteries of the millions of electric cars can be used to store electricity when they are inactive, and provide energy back to the grid to be used by other consumers.

Another issue at stake is the search of an optimum balance between individual and collective solutions. Cities want to capture the many sources of energy gushing in their midst rather than ignore them as they did in the past. But once captured, they have to integrate them into the power grid without destabilizing it. Thus, a key issue related to smart grids consists of finding the optimal balance between collective systems and area-specific solutions, which are often individual ones.

## **2. The emergence of a new function in the energy business**

### **2.1. A new professional capacity has to be fulfilled: “energy aggregator”**

An aggregator is an intermediary between the power system and the end-users. It manages energy distribution based on the electricity generated and consumed, acting like a “virtual power plant”. It helps to balance the grid in real-time. This improved control of electricity flows allows to anticipate peak consumption periods either by offloading some devices connected to the smart grid in order to artificially create additional capacity, or by starting backup generators available at other sites. This will smooth out the peaks and make the grid more effective, as well as ensure that large peak-load power stations - which emit huge quantities of greenhouse gas (GHG) - are switched on later or not at all. Aggregators generate local flexibility and create value for them and their clients by selling that flexibility to the power system.

## **2.2. Power storage is a major cog in smart grids, an essential piece of the puzzle for adding flexibility**

The power sector is one of the few industries that have no systematic storage system. In the US, 2.5% of the electricity produced is stored; in Japan, it is 15%. This means that power production must constantly equal consumption. The grid operator is responsible for keeping the two in balance.

To better regulate distribution and stabilize the grid, operators need to store electricity during off-peak periods and use buffer-stocks when the demand increases or when the source stops generating electricity (e.g. at night for solar technology). Efficient solutions have already been developed that are good enough to be deployed:

- In households: high-temperature batteries, hot water stored in tanks, etc.
- In buildings: photovoltaic panels, cold water stored into air-conditioning systems, etc.
- In communities: dams and water towers, since water is a pleasant way to store energy, etc.

Now it's time to organize the storage system on a larger scale. However, breakthroughs in decentralized storage technologies are still needed to optimize charge and discharge cycles, to reduce the cost of batteries and to better understand how storage devices age.

## **2.3. With smart grids, the energy business is redefined**

Smart grids are a new frontier for energy operators. To function in their roles, aggregators need to make the sites they manage "intelligent", to analyze energy consumer profiles, to write softwares to model the consumers' reactions to various situations (e.g. buildings, which function as micro-generators), to have information systems that can forecast the grid's future situation and leverage the availability of power created and to produce GHG emissions and climate data.

There is a need for a professional management of smart grids. If poorly designed or poorly managed, an electricity network may become an energy guzzler. When properly operated, it saves energy. No matter how much is invested in R&D, it will amount to nothing if the technologies invented are not used in a professional manner.

## **3. The "Réflexe" project**

### **3.1. There are a great many operational obstacles to overcome, if we are to generalize smart grids**

First, technical obstacles are:

- Disparities among technical equipments already installed;
- Designing sensors capable of collecting data on the energy consumption of all buildings, shutdown devices, protection systems, etc.;
- Information management systems: processing billions of data bits in real-time requires communication standards and interfaces capable of transferring all these data between the grid's different components on the one hand, and appropriate software capable of processing the data on the other; and
- stabilizing the grid, which is a major issue.

Secondly, socio-economic obstacles are:

- The price of smart meters (if totally borne by consumers);
- The abundance and complexity of data provided, which generates reluctance to use it;
- Uncertainties about the consumers' willingness to accept offloads during peak periods; and
- Few large-sized experiences of market mechanisms to pay or credit consumers for offloads.

### 3.2. *Réflexe is France's first smart grid*

*Réflexe* is short for “Réponse de flexibilité électrique”. This project was selected as one of the country’s “investments for the future”. It was given the green light in December 2010 by then Prime Minister. *Réflexe* is a smart grid project managed by engineers at Veolia and supported by specialists at Alstom, Sagemcom, CEA-INES and Supelec. This three-and-half-year project aims to demonstrate the practical and financial feasibility of smart grids. Located near the city of Nice, it connects some 20 sites, including offices, shops, a wastewater treatment plant, hotels and a solar power station.

The project is implemented in two phases:

- Taking a census of all the installations connected to the grid, such as air-conditioning and lighting systems. They will then be fitted with meters and communication technology to monitor their energy consumption and identify any spare capacity.
- Grid operation: the smart grid will be controlled by an aggregator to optimize total consumption. This phase will begin in 2012 and will last for over 2 years.

### 3.3. *Réflexe gives a glimpse of the decentralized, interactive and flexible power grid of the future*

This smart grid demonstration project has several objectives:

- To experiment connecting intermittent renewable energy to the grid;
- To act as a test-bed for consumer technology; and
- To develop business models for smart grids. We are not yet entirely sure where value will be created and which link in the chain should benefit from it: energy supplier, distributor, aggregator or the consumer.

In *Réflexe*, the aggregator will monitor the smart grid’s energy consumption, generation and storage:

- When demand is high, it may turn down the lighting, heating or air-conditioning in buildings it manages without affecting users’ comfort, or use energy stored during off-peak periods.
- During peak periods, *Réflexe* will provide at least 1MWh of added capacity to help smooth peak usage in the region.
- The aggregator will control equipments connected to the *Réflexe* grid, such as turbines powered by the water supply network of Nice. This will generate complementary power capacity by creating reserves of water upstream of the turbines, which could then be released to produce electricity on demand.

## 4. New economic models and new relations to customers induced by smart grids

### *What are the main features of the new economical models for electricity?*

Electricity economic models of the future will be local models, blending local resources with local uses. In the past, when we thought of energy, we thought of large capacity production units. It is no longer the case today. The 20<sup>th</sup> century saw the triumph of large power infrastructures. The 21<sup>st</sup> century will see a proliferation of small equipments decentralized at local level. Since energy sources will be located close to the needs, there will be less need to build high-voltage lines to transport electricity over long distances.

A give-and-take relationship between network operators and consumers is emerging. Smart grids induce deep changes in state/market relations and in utilities/subscribers relations. The million urban energy consumers will become temporary producers. Smart grids are going to transform both the meter and the bill.

The respective importance of electricity production and consumption will be reversed in future economic models. Managing demand will be the priority, supplanting the policies of endless expansion of production that have dominated in the past. Major challenges rely on small, daily decisions made by people on a daily basis. Smart grids will help them choose the right behavior and save energy.

#### **4.1. *Inventing new frameworks and economic models***

Eco-efficiency relies both on the quality of the equipments and the behavior of consumers. Besides technological innovations, we also need to think about the socioeconomic and organizational framework in which smart grids can be set up.

Outlets are already in existence, which is a key point. The issue at hand is still the economical signals given to domestic users to produce, consume and invest: it should be clear enough and easily understandable. The incentives to encourage customer investments in renewable forms of on-site power generation should be significant. The incentives for consumers to accept to reduce their energy consumption during peak periods should also be significant.

Economic models should split gains between consumers and the service operators, to encourage the first ones to reduce their consumption during peak periods.

Public authorities, energy utilities and aggregators have to:

- Create new economic models that are flexible enough to leverage the full potential of local power production; and
- Identify the factors likely to make households behave as if they were stakeholders in the system, notably in terms of controlling their energy use.

#### **4.2. *Bringing more intelligence into electricity networks and economic circuits***

Smart grids make it possible to generalize the shift from a volume-based economy to one based on “no-volumes” that remunerates energy resources saved. The underlying economic logic here is to encourage some clients to make energy savings -via a specific remuneration system- and then to use the energy saved to supply other clients.

Many of the renewable energies and smart grids will not be developed up to their promising potential without establishing appropriate pricing policies. Too often, renewable energies and smart grids turned out to be too expensive because of competition from undervalued conventional sources (e.g.: coal in China). It makes the bankability of some smart grid project low. For some renewable energy and smart grid projects, an economic model independent of subsidies is still a work in progress.

## **5. Conclusion: Smart grids are a path to cleaner electricity and a step towards smart cities**

We are at the very beginning of smart grids. Much progress in this area is still needed to “tame” renewable energies and to reap benefit from the promising potential. Smart grids will create a breakthrough in the electricity sector, equivalent to the one created by the Web in the telecommunications sector.

*“For smart grids to be really useful, they must be “smart” across national borders as well as across borders within different jurisdictions within a country. [...] Grid technology must be coordinated and to a large extent be interchangeable”* (Kimberly G. et al., 2011).

Smart grids are a component of the city of tomorrow; a city that will be more connected, more informed and more intelligent.

### Reference

Kimberly, Gray, Douglas Farr and David Dana, *Living cities. Transforming APEC cities into models of sustainability by 2030*, 2011



## AMI-ADEME and APP-IEED: French government initiatives on MRE

**AMI-ADEME: Invitation for Expression of Interest by the French Agency for Environment and Energy Management**

**AAP-IEED: Call for Projects by Institutes of Excellence in Carbon-Free Energies, French Marine Energies**

Marc Le Boulluec, Research Engineer, IFREMER, France

### 1. Emergence of the marine renewable energy sector in France: a long story

The first attempt to build a large-scale marine renewable energy prototype at sea for Ocean Thermal Energy Conversion (OTEC) started in the '30s and continued until the '50s, headed by Georges Claude. Later on, an OTEC plant was studied in the '80s by IFREMER and an industrial consortium, Ergocéan. The project stopped in 1986 because of the global reduction in oil price.

In the early '60s, a 240 MW tidal plant was built in the Rance natural firth where the tidal potential was exploited since the late Middle Ages through tidal mills. Since 1967, this tidal energy plant has produced around 0.5 TWh per year.

In the '70s and '80s, wave energy was studied by Ecole Nationale Supérieure de Mécanique de Nantes (today Ecole Centrale de Nantes) and IFREMER organised a wave energy “contest” with the review of various proposals and concepts. From 1986 to end of the '90s, there was a “valley of death” for marine renewable energies in France.

In 2002, a joint-ministerial report was headed by the Secrétariat Général de la Mer (SGMER), giving recommendations for the development of wind energy at sea. From 1999 to 2004, several offshore wind energy projects were studied without realization. Two current energy device projects were approved by Pôles Mer (regional competitiveness networks) in 2005 and Tenerrdis (energy cluster) in 2006.

First tariffs for wind energy and marine renewable energy were promulgated in 2006 and 2007 in France and around Europe. A first zoning tool for public services was published in 2007 by ADEME (French Environment and Energy Management Agency) and in 2008 IFREMER published an outlook study on marine renewable energy (MRE), with a horizon of up to year 2030.

From 2007 to 2008, the Grenelle de l'Environnement (Environment Roundtable) gave rise to proposals for research demonstration funds including MRE (<http://www.legrenelle-environnement.fr>).

### 2. Since 2008: Structuring the marine renewable energy sector

In 2008, a public-private partnership (PPP) initiative for MRE emergence was launched, gathering 138 public and private sector partners (<http://www.ipanema2008.fr>) and one report was published.

The Grenelle de la Mer<sup>1</sup> was held in 2009, which defined some priorities: *Plan Energies Bleues* (“Blue Energies Plan”), demonstrators’ support, importance of French overseas territories, as well as need for test-sites. In the same year, important decisions were made for funding the marine renewable energies development in France.

### 2.1. AMI-ADEME

A research demonstrator fund managed by ADEME was set up and an invitation for expression of interest (“appel à manifestation d’intérêt”) received 21 bids. Five outstanding projects were selected: two on floating wind turbines, two on current turbines and one on wave energy conversion. IFREMER is a partner in four of these five projects. These projects gather partners from heavy industry fields, engineering consulting firms in technology and environment, public institutes and universities. Demonstrators at sea are scheduled for 2013-2014.

### 2.2. AAP-IEED

On July 16<sup>th</sup> 2009, French President Nicolas Sarkozy announced the creation, in France, of a technological platform on MRE with IFREMER as a leader.

The “*Investissements d’Avenir*” (Investments for the Future) raised funds in favor of the creation of “*Instituts d’Excellence en matière d’Energies Décarbonées* (‘institutes of excellence in the field of carbon-free energy’) (IEED)” and a call for projects was made in 2010. The proposal for *IEED France Energies Marines (FEM)* was prepared during 2010-2012 and the announcement of IEEDs granted was done by the Prime Minister on March 11<sup>th</sup> 2012. France Energies Marines ([www.france-energies-marines.org](http://www.france-energies-marines.org)) is now in a preliminary phase. It is based on a public-private partnership involving more than 30 companies and 20 public entities representing all the key players of the MRE sector across the different coastal regions off mainland and France’s overseas territories.

FEM’s objective is to offer scientific and technological facilities for the industrial development of MREs:

- Offshore wind, tidal current, tidal range, wave energy, OTEC
- Build a world-class industrial leadership:
  - bring leading sectors together (off-shore oil & gas, shipbuilding, utilities, etc.)
  - promote the sustainability of technologies (European criteria)
- Consolidate scientific excellence:
  - multidisciplinary teams (as opposed to today’s specialized teams)
  - public-private synergies (various levels of technology development and maturity)
- Validate the technologies and reduce their costs:
  - prototypes/pre-commercial units and arrays (a range of services)
  - shared infrastructures (numerical modeling, test benches, 5 test sites)
- Support the industry through education and training:
  - define the appropriate training programs required
  - disseminate learning tools

### 2.3. Other prospective and decision making bodies

Since 2009, the National Alliance for Coordination of Research on Energy (ANCRE), led by academics, is coordinating the research activities in the field of energy. A roadmap on marine renewable energy is under construction.

In 2009 and 2010, MRE plans were underway by updating the decision-making tool of ADEME and coordinating the dialogue, with the aim to call for projects on offshore, ground-based wind turbines in 2011, under the heading of the regional and maritime prefects. Four projects have been selected,

<sup>1</sup> Environment Roundtable focusing on the sea, <http://www.legrenelle-environnement.fr/-Le-Grenelle-de-la-Mer-.html>

with a total installed capacity of 2,000MW. A second call for projects may be launched in 2012, including possible floating wind turbines and marine current turbines. New calls are scheduled for 2013.

## EMACOP (Energies MARines, COtières et Portuaires), A National Research Program for Coastal and Port Marine Energy

**Henri Boyé**, General Council for Environment and Sustainable Development, French Ministry of Ecology and Energy, Chairman of the EMACOP Project, France

### 1. Introduction

EMACOP is an acronym for “Energies Marines Cotières et Portuaires” (Coastal and Port Marine Energy), a French national research project on renewable marine energies in coastal and port areas.

Marine coastline and coastal zones are by nature dynamic and sensitive areas, exposed to natural phenomena of erosion and marine submersion, and also to human development. Seashore structures play a dual role: long-term protection of coastal areas and economic development submitted to a growing anthropic pressure.

France owns one of the longest littoral coastlines in the world. Today, the marine-installed base of coastal and port works is composed of very diverse structures. Many are aging and facing several classical seashore problems (stability, durability, and sediment dynamics) and also possible threats due to climate change. As coastal protection barriers, our ports and harbor structures, an asset and heritage, are aging. They must be developed and modernized, adapting to traffic growth and the increase in ship sizes. Moreover, anticipating the expected sea level rise and higher wave heights at the toe of coastal structures, an adaptation to climate change must be planned. This necessary adaptation will require investments, but it also provides an opportunity for the development of renewable energies and the reduction of green house gas emissions.

The recovery of wave energy will contribute to the concept of “clean harbor”, in the same spirit as “clean cities”, and sustainable development. This idea of a zero-emission port is developed in several new port terminals in the world. In addition to wind and solar energy, the future harbor should also use wave energy for its main energetic needs. This renewable energy will activate plugs along the quay and will directly reduce the gas emissions from ships during loading and unloading operations.

### 2. Objectives of the EMACOP research program<sup>2</sup>

#### 2.1. *Technical and economic assessment*

Perform a technical and economic assessment of the opportunity to integrate marine renewable energy (MRE) recovery on existing or new marine infrastructures: technological progress in harbors and coastal defenses of coastline and seashore, feasibility surveys and assessments of the potential of MREs - especially wave energy - , awareness of decision-makers and contracting owners (most often the local province or municipality).

#### 2.2. *Best-of-breed selection*

Select the best available technologies among wave and ocean current energy, designs and concepts; establish a state of the art technology, survey a wide range of experiences in order to retain the more mature and most promising technologies; assess performance and survivability; rank by family, by performance in energy absorption, develop tools.

---

<sup>2</sup> See: <http://www.emacop.fr>

### **2.3. Coordination**

For the first time, there is a coexistence of two functions: protecting against marine stimuli and energy recovery. The challenge of EMACOP is to develop an inclusive vision, linking design and construction, economic implications and social acceptability.

Sea and ocean are no longer an adversary one needs to be protected from, but an energy resource that can be harvested in a friendly and realistic way.

## **3. Structure of EMACOP**

EMACOP's structure is that of a matrix organization, with various tasks and partners. EMACOP involves various French partners: technical, engineering, research, ports, corporations, local municipalities, etc. The project entails cooperative financing (budget of around US\$7 million) over a period of four years. Henri Boyé was nominated chairman of the EMACOP project in February 2012, with Philippe Sergent (Centre d'Etudes Techniques Maritimes et Fluviales (CETMEF)) as technical director and Alain Clément (École Centrale de Nantes) as scientific director.

## **4. The EMACOP project: Concrete examples**

### **4.1. Wave energy**

Technical and economical assessment of the wave energy systems for the existing maritime structures of different sorts: dykes made of natural riprap and artificial concrete, vertical dykes, breakwater, pier, jetty with perforation.

### **4.2. Piers and jetties**

Existing piers and jetties cover, 180km in length in France. Illustrations: the Harbor of Cherbourg, the Antifer oil terminal near Le Havre, the dike at sea of l'Artha in Saint-Jean de Luz, the Pier of Roscoff, coastal road with embankment in the Reunion Island.

### **4.3. Sea and seashore systems**

Current energy systems at sea, seashore and big bridges (Pont de l'Atlantique across the estuary of the Seine River and bridges to the islands of Ré and Noirmoutier).

### **4.4. River sites<sup>3</sup>**

It is interesting to consider the recovery of tidal energy in some available water locks (for example, the harbor of Le Havre Sas Quinette de Rochemont, an area of 0.5km<sup>2</sup> and a potential tidal power of 500kW).

---

<sup>3</sup> E.g. Bordeaux bridges in river environment under tidal influence. See:

<http://www.ecocinetic.fr>

<http://www.tocardo.com>

<http://www.c-energy.nl>

<http://www.hydrogen.fr>

<http://www.blueenergy.com>

<http://www.gazintegral.com/blustream>

## 5. EMACOP's mandate

### 5.1. *Select the best adequate technologies*

- Ocean current energy designs and concepts, state-of-the-art technologies, benchmarks, survey of a wide range of experiments in order to retain the more mature and most promising technologies.
- Assessment of performance
- Ranking by family
- Ranking by performance in energy absorption
- Tools development

### 5.2. *Performance assessment*

- Estimated yearly energy produced on site - income
- Estimation of generated energy with respect to system mass ratio
- Estimation of generated energy with respect to system wet surface ratio
- Manufacturing and construction costs

### 5.3. *Performance survey*

- Analysis through benchmark of data and figures
- Critical data analysis
- Development of computing models if the data searched in scientific literature is insufficient or unavailable
- Physical and numerical modeling

### 5.4. *Survivability survey*

- Computer models developed for the study of performance used to extrapolate the maximum forces and the standard deviation of efforts dimensioning
- Tank-tests on a small-scale.

### 5.5. *Prediction modeling*

- Improvement in knowledge and prediction of resource in wave energy in coastal areas (cartography, temporal variability, etc.)
- Climatology of the waves, as essential data for the selection and choice of the best sites for wave devices or wave energy farms
- Estimating the theoretical maximum power that could be recovered on a site once a system concept of wave energy and its characteristics are known

### 5.6. *Testing*

- Studies of design and survivability of the system (in extreme conditions), studies of fatigue
- Site accessibility
- Production forecast in operational conditions

### 5.7. *Coexistence of the two functions*

- Protection against marine stimuli
- Energy recovery

### 5.8. *Develop an inclusive vision*

- Design and construction
- Economic implications
- Social acceptability

### **5.9. Societal impact**

- Spatial optimization
- Multipurpose territorial usage
- Conflicts of use (navigation, fishing from the shore)
- Local consumption of energy
- Visibility of devices at low tide
- Curiosity and danger for the public (industrial tourism)
- Noise

## **6. Conclusion**

The EMACOP research program aims to manage the coexistence of the two main functions of port and harbor infrastructures: protecting against marine aggression and energy recovery. It intends to do so with the development of an inclusive vision, linking design and construction, economic implications, and social acceptability.

As coastal protection, our port and harbor infrastructures are aging. They must be developed and modernized, adapted to traffic growth and ship size increase. This necessary adaptation will require investments, but at the same time provides an opportunity, at a marginal additional cost (as there is no expense for the existing infrastructures), to develop renewable energies and reduce green house gas emissions.

Can we imagine using the wave energy on a wide scale for the energy needs of harbors and cities close to the sea? Is a “zero-emission” harbor possible, a “clean harbor” in the spirit of “clean cities,” and sustainable development?

A challenge of EMACOP will be to involve all partners in this project as stakeholders, contract owners in charge of the management of the French ports and decision makers, and to develop their awareness to clean technologies, marine renewable energies and in particular wave energy.